

# AN050: TMCS-xx Mounting Manual

Document Revision V1.00 • 2018-Aug-31

**This application note describes how to mount the Trinamic TMCS-XX encoder.**

## Contents

<b>1</b>	<b>Introduction</b>	<b>1</b>
<b>2</b>	<b>Parts included</b>	<b>2</b>
2.1	Hex key . . . . .	2
2.2	Spacer tool . . . . .	2
2.3	Housing and electronics . . . . .	2
2.4	Encoder disc . . . . .	3
2.5	Alignment tool . . . . .	3
2.6	Bottom plate . . . . .	3
2.7	Cable loom . . . . .	3
<b>3</b>	<b>Parts needed</b>	<b>4</b>
3.1	Screws . . . . .	4
3.2	Screwdriver . . . . .	4
3.3	Stepper Motor . . . . .	4
<b>4</b>	<b>Mounting the encoder</b>	<b>5</b>
4.1	Step 1: Adding the bottom plate . . . . .	5
4.2	Step 2: Aligning the bottom plate . . . . .	6
4.3	Step 3: Securing the bottom plate in place . . . . .	7
4.4	Step 4: Removing the alignment tool . . . . .	8
4.5	Step 5: Placing the spacer tool . . . . .	9
4.6	Step 6: Placing the encoder disc . . . . .	10
4.7	Step 7: Removing the spacer tool . . . . .	11
4.8	Step 8: Securing the encoder housing in place . . . . .	12
<b>5</b>	<b>Conclusion</b>	<b>13</b>
<b>6</b>	<b>Related products</b>	<b>14</b>
<b>7</b>	<b>Revision History</b>	<b>14</b>

## 1 Introduction

This application note describes how to mount the Trinamic TMCS-XX encoder.



## 2 Parts included

For mounting any of Trinamic's encoders, you need the following parts as described below. While most parts are included in the TMCS-XX-KIT, you will also need some additional parts as described in section 3 of this document.

### 2.1 Hex key

A small hex key is included with the TMCS-XX encoder. You will find this tool in a small bag together with the spacer tool and alignment tool.



Figure 1: Hex tool

### 2.2 Spacer tool

Use this tool to adapt the distance between encoder disc and electronics. For some, these spacers are transparent and made of plastic. For other encoder kits, these spacer tools are metal sticks shaped accordingly. You will find this tool in a small bag together with the alignment tool and hex key.



Figure 2: Spacer tool

### 2.3 Housing and electronics

Housing with pre-mounted electronics.



Figure 3: Housing and electronics



## 2.4 Encoder disc

Please handle the encoder disc with care.



Figure 4: Encoder disc

## 2.5 Alignment tool

Required in order to align the housing to the motor shaft. Please note that the alignment tool provided might have a different color than depicted below. You will find this tool in a small bag together with the spacer tool and hex key.



Figure 5: Alignment tool

## 2.6 Bottom plate

The bottom plate fixates the encoder to the motor. Please note that the bottom plate provided in the kit might look different from the one depicted here. It can either be of plastic or metal, and has two screw holes in it. You will find the bottom plate next to the encoder disk and the housing and electronics, each safely placed in its own space.



Figure 6: Bottom plate

## 2.7 Cable loom

Cable loom for connecting the encoder.

The supplied cable loom has a connector on one end to plug into the encoder, and clean-cut wires on the other end. The signals and connection of the cable loom can be found in the datasheet of the encoder in question.



## 3 Parts needed

Please note that the encoder only contains the parts listed above. In order to mount it on a stepper motor, you should make sure to have a few additional parts.

### 3.1 Screws

Screws to fixate the encoder housing to the motor.

Please note that the screws are not included. Make sure to select the screws according to the drills in your motor.



Figure 7: Screws

### 3.2 Screwdriver

In order to put the screws tightly in place, a small Phillips head screwdriver is needed.

### 3.3 Stepper Motor

Stepper motor with double shaft.

Please make sure to find a mating motor or to modify a motor that provides the required drills to mount the encoder. There is no common standard, so a custom modification might be necessary.

Please refer to the datasheet of the encoder in question for the corresponding alignment of drills.

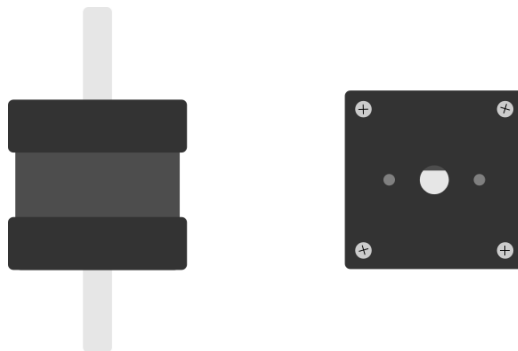

Figure 8: Stepper motor with double shaft



## 4 Mounting the encoder

The following explains how to mount the Trinamic TMCS-XX encoder to a motor with double shaft in 8 easy to follow steps.

If the encoder kit you ordered contains more than one encoder, it is important to use the correct hex key, spacer tool, and alignment tool provided. You can find out which set of tools to use from the small sticker on the bag of tools.

### 4.1 Step 1: Adding the bottom plate

Slide the bottom plate on the motor shaft and align the screw holes to the drillings in the motor's back bell.

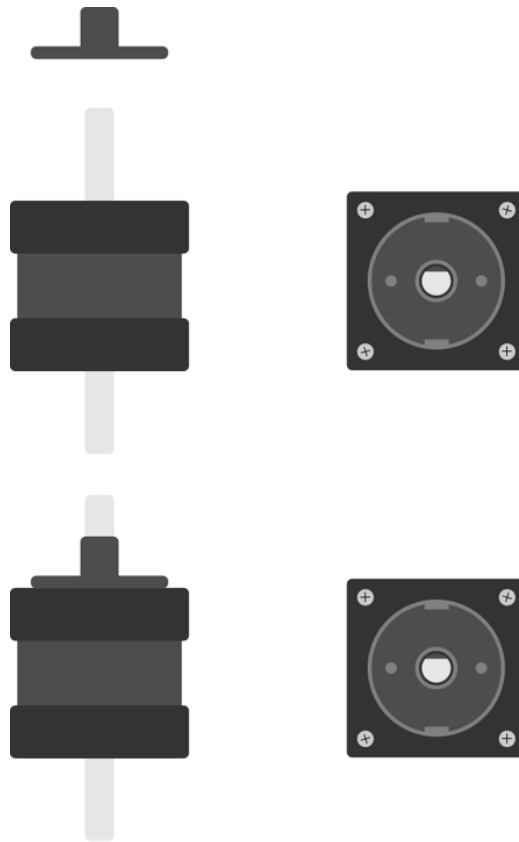

Figure 9: Step 1 of mounting the TMCS-XX



## 4.2 Step 2: Aligning the bottom plate

Slide the alignment tool on the motor shaft.

This will make sure that the bottom plate is perfectly aligned to the motor shaft.

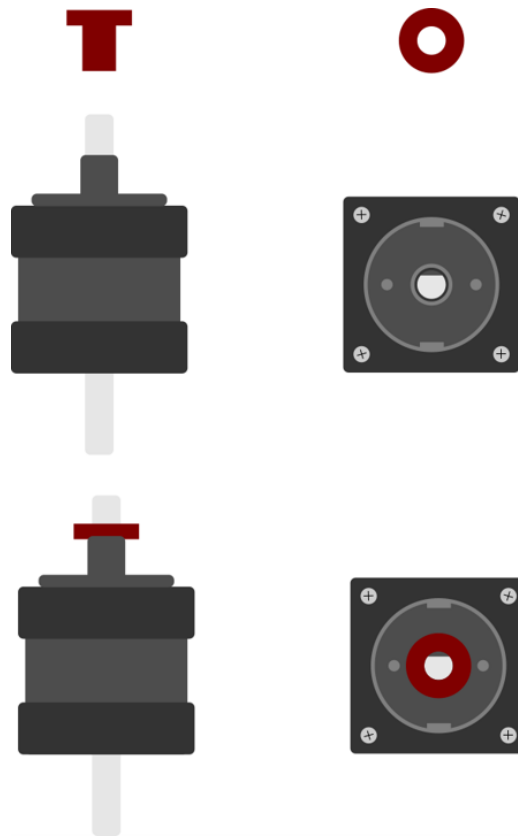

Figure 10: Step 2 of mounting the TMCS-XX

### 4.3 Step 3: Securing the bottom plate in place

Fixate the bottom plate with the screws.

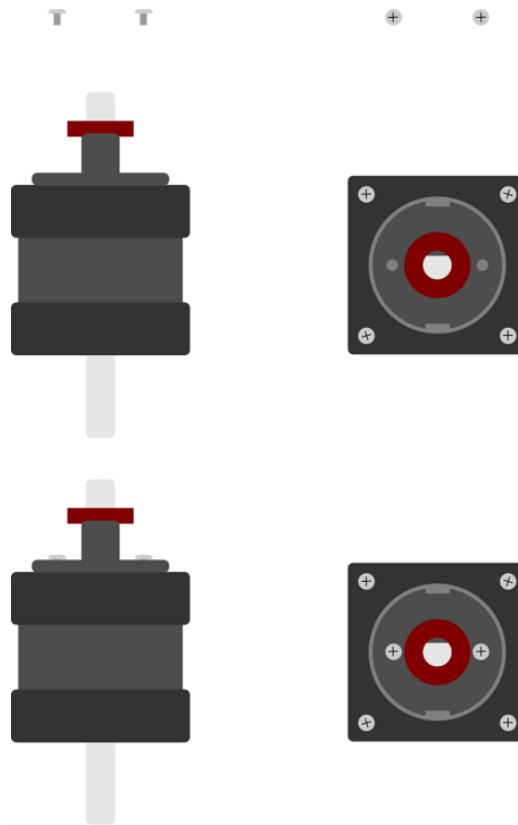

Figure 11: Step 3 of mounting the TMCS-XX



#### 4.4 Step 4: Removing the alignment tool

Remove the alignment tool.

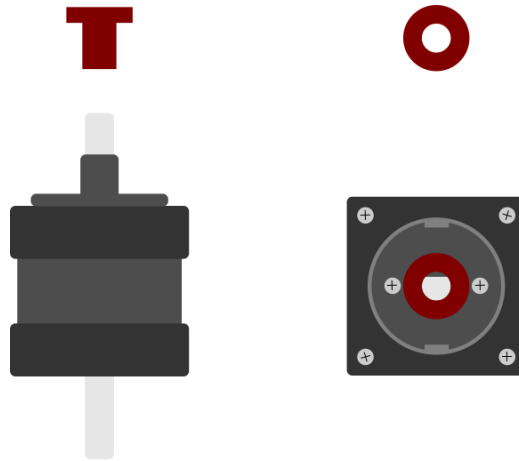

Figure 12: Step 4 of mounting the TMCS-XX





## 4.5 Step 5: Placing the spacer tool

Place the spacer tool on the motor. If you have a C-shaped spacer as depicted in this application note, be sure to place it around the motor shaft.

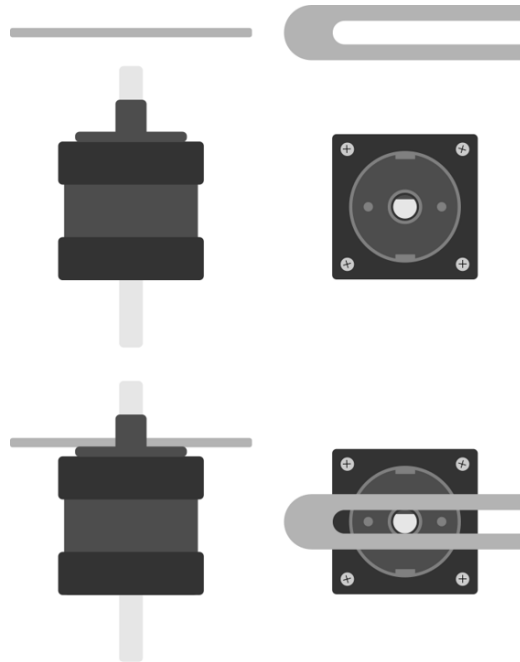

Figure 13: Step 5 of mounting the TMCS-XX



## 4.6 Step 6: Placing the encoder disc

Slide the encoder disc on the motor shaft and press it together with the spacer against the bottom plate. Now fixate the encoder disc on the motor shaft using the small hex key that's provided.

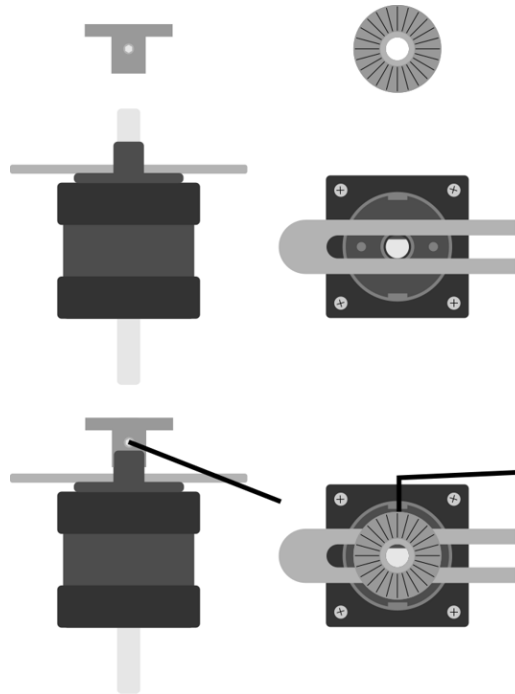

Figure 14: Step 6 of mounting the TMCS-XX

## 4.7 Step 7: Removing the spacer tool

Remove the spacer tool.

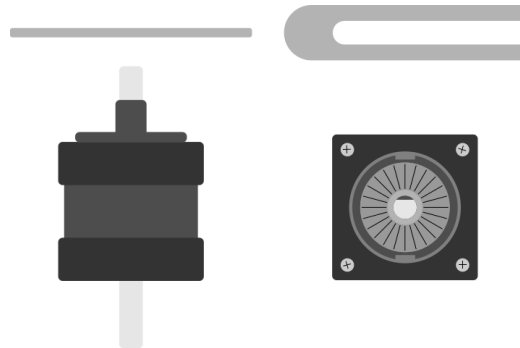

Figure 15: Step 7 of mounting the TMCS-XX



## 4.8 Step 8: Securing the encoder housing in place

Fasten the encoder housing on the bottom plate.

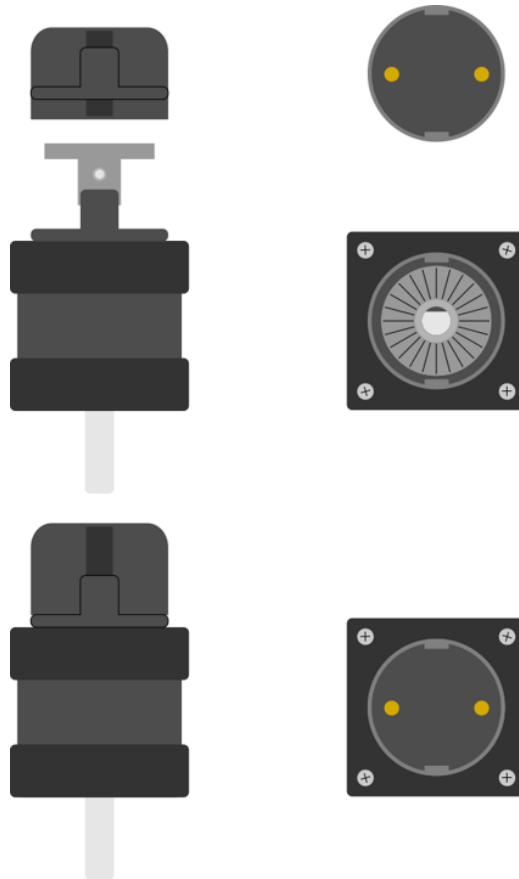

Figure 16: Step 8 of mounting the TMCS-XX



## 5 Conclusion

Trinamic's TMCS-XX are low-cost optical incremental encoders with a small form-factor. Once mounted on your stepper motor with a double shaft, you're ready to go. Simply connect the provided cable and get started.



## 6 Related products

Order Code	Resolution	Housing Diameter
TMCS-20-KIT	32768 increments	20mm
TMCS-28-KIT	40000 increments	28mm
TMCS-40-KIT	40000 increments	40mm

*Table 1: Related products*

## 7 Revision History

Version	Date	Author	Description
V1.00	31.08.2018	TE	first version

*Table 2: Document Revision*

