

# TMCM-102

## Standard Add-On-Board

### Manual



Version: 1.00  
June 13, 2007



Trinamic Motion Control GmbH & Co KG  
Sternstraße 67  
D - 20 357 Hamburg, Germany  
<http://www.trinamic.com>

# Contents

1	Features.....	4
2	Life support policy.....	5
3	Electrical and Mechanical Interfacing.....	6
3.1	Dimensions.....	6
3.2	Connectors.....	6
3.3	Connecting the Module.....	7
3.3.1	Add-on-board Connector 1 (Terminal).....	7
3.3.2	Add-on-board Connector 2 / Base Connector 2 (CAN & SPI).....	8
3.3.3	Add-on-board Connector 3 / Base Connector 3.....	8
3.3.4	Add-on-board Connector 4 (D-SUB).....	9
3.4	DIP switches.....	9
3.4.1	Switch 100 - Mode and interface addresses setting.....	10
3.4.2	Switch 101 - Interface selection 1.....	10
3.4.3	Switch 102 - Interface selection 2.....	10
4	Operational Ratings.....	11
5	Functional Description.....	12
5.1	System Architecture.....	12
5.2	Interface Selection through DIP switches.....	12
5.2.1	RS422 Configuration.....	12
5.2.2	RS232 Configuration.....	13
5.2.3	CAN Configuration.....	13
5.2.4	RS485 Configuration.....	13
5.2.5	USB Configuration.....	13
5.3	Interface address setting through DIP switches - not yet completed in firmware.....	13
5.4	Software selection through DIP switches - not yet completed in firmware.....	14
5.5	IN8 setting by DIP switch.....	14
5.6	Encoder connection.....	14
5.7	Reference switches.....	14
5.8	LEDs.....	14
6	Revision History.....	15
6.1	Documentation Revision.....	15
6.2	Firmware Revision.....	15
7	References.....	15

---

## List of Figures

Figure 3.1: Dimensions.....	6
Figure 3.2: The TMC-102 module and its connectors.....	7
Figure 3.3: DIP switches .....	9
Figure 5.1: Main parts of the TMC-102 add-on-board.....	12

## List of Tables

Table 1.1: Order codes.....	4
Table 3.1: Add-on-board Connector 1 (Terminal).....	7
Table 3.2: Add-on-board Connector 2 / Base Connector 2 (CAN & SPI).....	8
Table 3.3: Add-on-board Connector 3 / Base Connector 3.....	8
Table 3.4: Add-on-board Connector 4 (D-SUB).....	9
Table 3.5: Switch 100 – Mode and interface address setting .....	10
Table 3.6: Switch 101 – Interface selection 1.....	10
Table 3.7: Switch 102 – Interface selection 2 .....	10
Table 4.1: Operational Ratings .....	11
Table 5.1: LEDs .....	14
Table 6.1: Documentation Revisions .....	15
Table 6.2: Firmware Revisions.....	15

# 1 Features

The TCM-102 standard add-on board adds a number of communication interfaces to the TCM-102 and makes several I/O signals (including encoder interface / reference switch / input / output signals) available through easy to use spring clips (which are otherwise just available through the on-board 2-row female connector).

## Applications

- add-on board for the TCM-102 controller / driver
- interfaces and module addresses selectable through DIP switches

## Electrical data

- power supply through TCM-102 base board
- +5V output (50mA) on spring connector

## Interface

- either RS422, RS232, CAN, RS485 or USB
- selection of interface by onboard DIP switches
- additional DIP switches for address setting (RS485 and CAN)
- 3 optically isolated inputs (Limit A and Limit B and IN9) for reference switches
- encoder interface (A/B/N), single ended + encoder power supply (+5V, 50mA max.)
- 2 general purpose digital outputs
- 

## Other

- RoHS compliant

Order code	Description
TMC-102-IF	TMC-102 with standard add-on board with 1-axis controller / driver 3.5A / 48V (standard)

**Table 1.1: Order codes**

---

## 2 Life support policy

TRINAMIC Motion Control GmbH & Co. KG does not authorize or warrant any of its products for use in life support systems, without the specific written consent of TRINAMIC Motion Control GmbH & Co. KG.

Life support systems are equipment intended to support or sustain life, and whose failure to perform, when properly used in accordance with instructions provided, can be reasonably expected to result in personal injury or death.

© TRINAMIC Motion Control GmbH & Co. KG 2007

Information given in this data sheet is believed to be accurate and reliable. However no responsibility is assumed for the consequences of its use nor for any infringement of patents or other rights of third parties, which may result from its use.

Specifications subject to change without notice.

## 3 Electrical and Mechanical Interfacing

### 3.1 Dimensions

In combination with a base board the overall height is increased to at least 33mm. Be aware that the RS232 connector of the add on board is upright.

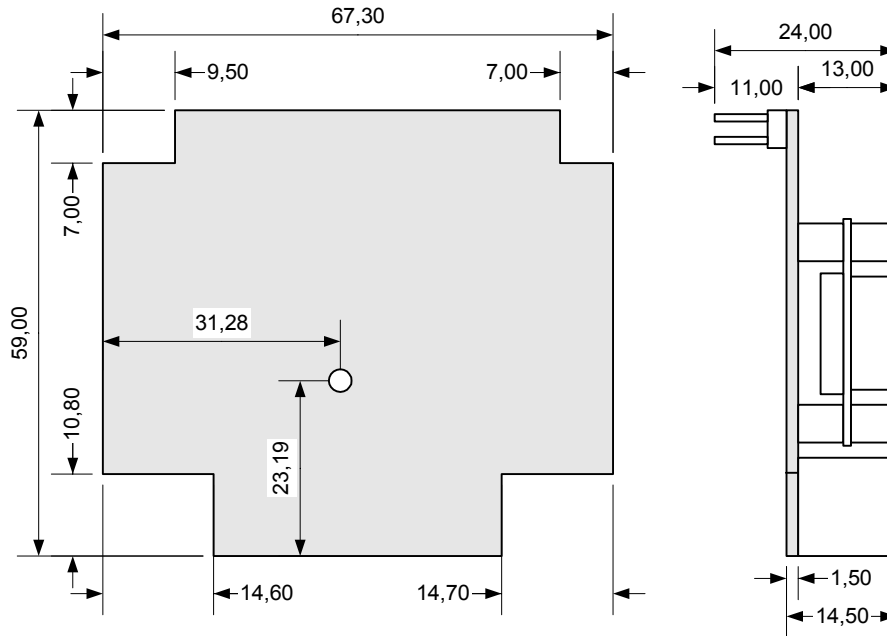

Figure 3.1: Dimensions

### 3.2 Connectors

The connectors onboard the TCM-102 Add-On-Board are

Connector 1: 14 pole terminal (PHOENIX\_FFKDSH-254-14)

Connector 2: D-SUB, female

Connector 3: STILEI-2x17\_jumper, (2.54mm pitch pin connector)

Connector 4: STILEI-2x4\_jumper, (2.54mm pitch pin connector)

USB-type-B\_4\_H, USB type B socket, horizontal

### 3.3 Connecting the Module

The TMCM-102 module consists of two PCBs: the base board and the adapter board. There are different add-on-boards available or can be customized for your demands.

**Never connect or disconnect the modules from each other while they are powered.**

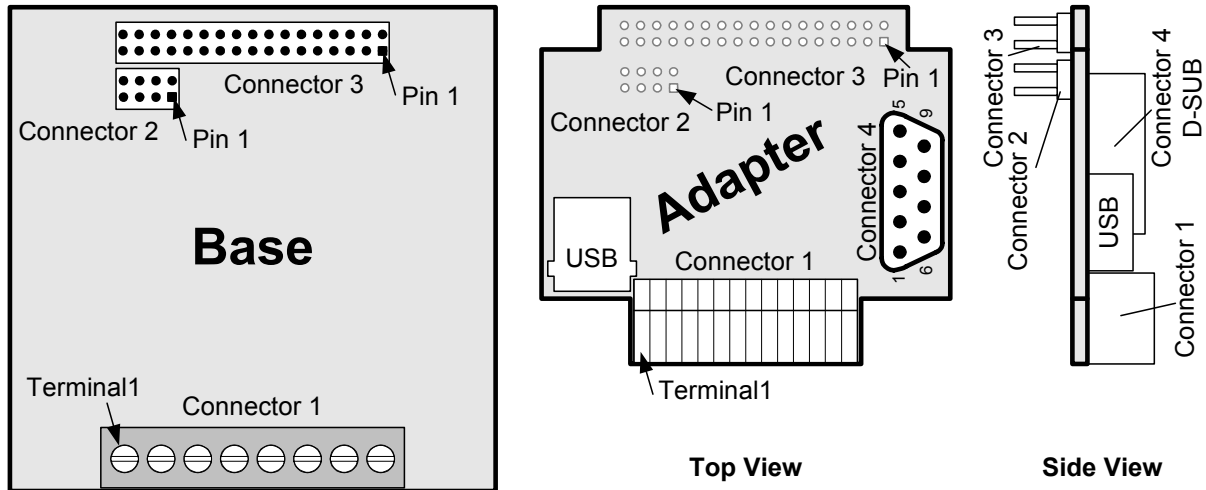

Figure 3.2: The TMCM-102 module and its connectors

#### 3.3.1 Add-on-board Connector 1 (Terminal)

Terminal	Name	Function
1	Opto+5V	Input: +5V power supply for onboard optocouplers to enable IN8, IN9, Limit A and Limit B
2	GND	Ground
3	Limit A	Optically isolated (on base board), active low limit switch input "Right"
4	Limit B	Optically isolated (on base board), active low limit switch input "Left"
5	IN9	Optically isolated (on base board), active low input IN9
6	OUT_1	User controlled output #1. No internal resistors. Powers blue LED.
7	OUT_2	User controlled output #2. No internal resistors. Powers blue LED.
8	IN1_A/D	User controlled input #1. No internal resistors.
9	S_Stop	Active low input to stop indexing using acceleration ramp.
10	+5V	Output: +5V power supply, 50mA max.
11	ENC_A+	Encoder input A+ for single ended encoders, TTL levels
12	ENC_B+	Encoder input B+ for single ended encoders, TTL levels
13	ENC_N+	Encoder input N+ for single ended encoders, TTL levels
14	GND	Ground

Table 3.1: Add-on-board Connector 1 (Terminal)

### 3.3.2 Add-on-board Connector 2 / Base Connector 2 (CAN & SPI)

Pin	Name	Function	PIN	Name	Function
1	CANH	CAN input High	2	MISO	SPI serial input (master in slave out)
3	CANL	CAN input Low	4	MOSI	SPI serial output (master out slave in)
5	GND	Ground	6	SPI_CLK	SPI serial clock
7	+5V	+5V supply	8	CS_EXT	SPI low active device select

Table 3.2: Add-on-board Connector 2 / Base Connector 2 (CAN & SPI)

### 3.3.3 Add-on-board Connector 3 / Base Connector 3

Pin	Name	Function	PIN	Name	Function
1	TX-	RS422 Transmit - (data out from indexer)	2	TX+	RS422 Transmit + (data out from indexer)
3	RX-	RS422 Receive - (data into indexer)	4	RX+	RS422 Receive + (data out from indexer)
5		Internally pulled down via 2k7 resistor. Not supported by TMCL.	6	IN1_A/D	Analog user controlled input #1. No internal resistors.
7	REF R	Optically isolated, active low limit switch input "Right"	8	STEP_OUT/RXD	Step clock output from indexer RS232 option: RS232 receive
9	OUT_2	User controlled output #2. No internal resistors.	10	DIR_OUT/TXD	Direction output from indexer. RS232 option: RS232 transmit
11	IN8	Digital user controlled input #8. Optically isolated, active low (needs power supply on pin 15)	12	ENC_A-	Differential encoder: Channel A-input (optional)
13	IN3_A/D	Analog user controlled input #3. No internal resistors.	14	ENC_B-	Differential encoder: Channel B-input (optional)
15	+5V	DC bias for input opto couplers	16	+5VDC	Logic supply out for encoder
17	OUT_1	User controlled output #1. No internal resistors.	18	ENC_N-	Differential encoder: Channel N-input (optional)
19	REF L	Optically isolated, active low limit switch input "Left"	20	GND	Logic supply ground connection
21	IN4	Digital user controlled input #4. No internal resistors. (TTL)	22	OUT_3	User controlled output #3. No internal resistors.
23	IN9	Digital user controlled input #9. Optically isolated, active low (needs power supply on pin 15)	24		Not supported by TMCL.
25	IN6	Digital user controlled input #6. No internal resistors. (TTL)	26	IN2_A/D	Analog user controlled input #2. No internal resistors.
27	ALARM	High voltage open collector output indicating driver fault condition.	28		Not supported by TMCL.
29	ENC_N+	Encoder option: Single ended: Channel N input Differential: Channel N+ input	30	IN7	Digital user controlled input #7. No internal resistors. (TTL)
31	FS	Active for one clock pulse at each on-pole fullstep position.	32	IN5	Digital user controlled input #5. No internal resistors. (TTL)
33	ENC_B+	Encoder option: Single ended: Channel B input Differential: Channel B+ input	34	ENC_A+	Encoder option: Single ended: Channel A input Differential: Channel A+ input

Table 3.3: Add-on-board Connector 3 / Base Connector 3

### 3.3.4 Add-on-board Connector 4 (D-SUB)

The DIP switch setting (refer to 5.2) controls the signals/interface off the D-SUB connector.

Terminal	CAN	RS232	RS485	RS422
1				
2	CANL	RXD	RS485-	TX-
3	GND	TXD		
4				RX-
5	GND	GND	GND	GND
6				
7	CANH		RS485+	TX+
8				RX+
9				

Table 3.4: Add-on-board Connector 4 (D-SUB)

## 3.4 DIP switches

DIP switch 100 adjusts the address of the CAN and RS-422 interfaces. Only one of these interfaces can be used at a time. Switch 101 and 102 select the different interfaces (RS422 or RS232, CAN, RS485 and USB).

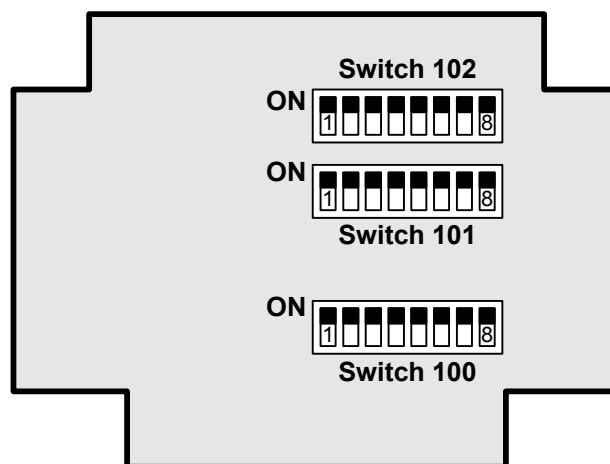

Figure 3.3: DIP switches

### 3.4.1 Switch 100 - Mode and interface addresses setting

Switch	Name	Function
1	IN8	ON: optocoupler active (if +5V at pin 15) -> IN8 is ON OFF: IN8 is OFF
2	SeISW_o	Select software TMCL / CANopen / IMS_clone
3	SeISW_1	Select software TMCL / CANopen / IMS_clone
4		Interface address setting, Refer to 5.3 - tbd
5		Interface address setting, Refer to 5.3 - tbd
6		Interface address setting, Refer to 5.3 - tbd
7		Interface address setting, Refer to 5.3 - tbd
8		Interface address setting, Refer to 5.3 - tbd

Table 3.5: Switch 100 – Mode and interface address setting

### 3.4.2 Switch 101 – Interface selection 1

For further information how to activate different interfaces refer to 5.2.

Switch	Name	Function
1	CAN L	CAN Low
2	CAN H	CAN High
3	GND	CAN ground
4	232-RXD	RS232 RxD (input)
5	232-TXD	RS232 TxD (output)
6	TX+	RS232 and USB conjunction
7	RX+	USB conjunction
8	RX+	RS232 conjunction

Table 3.6: Switch 101 – Interface selection 1

### 3.4.3 Switch 102 – Interface selection 2

For further information how to activate different interfaces refer to 5.2.

Switch	Name	Function
1	Term	Termination of CAN, RS485 and RS422 (TX+, TX-)
2	TX+	RS485 (+) / RS422 (output)
3	TX-	RS485 (+) / RS422 (output)
4	RX-	RS485 (-)
5	RX+	RS485 (-)
6	RX+	RS422 (input)
7	RX-	RS422 (input)
8	Term	Termination of RS422 RX+ and RX- only

Table 3.7: Switch 102 – Interface selection 2

## 4 Operational Ratings

The operational ratings show the intended / the characteristic range for the values and should be used as design values. In no case shall the maximum values be exceeded.

Symbol	Parameter	Min	Typ	Max	Unit
$U_{+5V}$	+5V output (max. 150mA load)	4.8	5.0	5.2	V
$V_{ISO}$	Isolation voltage of optocoupler		$\pm 42$	$\pm 100$	V
$V_{OPTON}$	Signal active voltage at enable, step and direction input (optocoupler on)	4	5	5.2	V
$I_{OPTON}$	Signal current for optocoupler (internally limited)	2.5	15	30	mA
$V_{OPTOFF}$	Signal inactive voltage at enable, step and direction input (optocoupler off)	-1	0	1.5	V
$V_{ANA}$	GPIO analog measurement range (20k voltage divider in high range)		0 ... 5 0 ... 10		V
$V_{STOPLO}$	StopL, StopR low level input		0	0.9	V
$V_{STOPHI}$	StopL, StopR high level input (integrated 10k pullup to +5V)	1.9	5		V
$T_{ENV}$	Environment temperature at rated current (no cooling)	-40		+60	°C
	Environment temperature at 80 % of rated current or 50% duty cycle (no cooling)	-40		+80	°C

**Table 4.1: Operational Ratings**

# 5 Functional Description

In Figure 5.1 the main parts of the TCCM-102 add on module are shown in combination with the TCCM-102 base board. The module mainly consists of the interfaces and connectors to get access to the base boards functions.

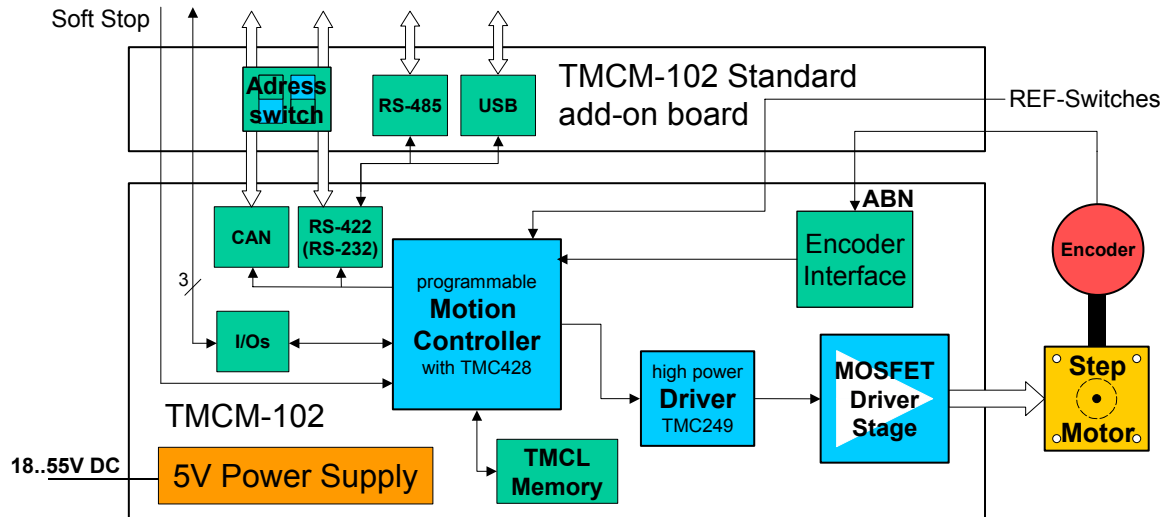

Figure 5.1: Main parts of the TCCM-102 add-on-board

## 5.1 System Architecture

With the adapter board the large amount of possibilities provided by the base board can be customized and easily accessed.

The standard adapter board provides five interface variants, RS422, RS485, CAN, RS232 and USB, witch can be adjusted via onboard dip switches. Also it has 14 easy accessible I/Os such as limit switches, encoder interface, etc.

## 5.2 Interface Selection through DIP switches

Switch 101 and 102 select the different interfaces (RS422 or RS232, CAN, RS485 and USB).

### 5.2.1 RS422 Configuration

To select the RS422 interface, configure the DIP switches 101 and 102 as follows:

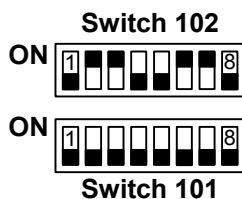

Additionally the termination can be activated by changing switch 1 and 8 of Switch 102 to ON.

### 5.2.2 RS232 Configuration

To select the RS232 interface, configure the DIP switches 101 and 102 as follows:

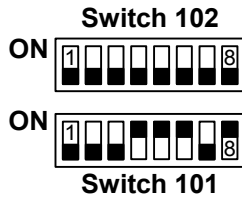

### 5.2.3 CAN Configuration

To select the CAN interface, configure the DIP switches 101 and 102 as follows:

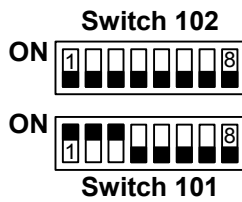

Additionally the termination can be activated by changing switch 1 of Switch 102 to ON.

### 5.2.4 RS485 Configuration

To select the RS485 interface, configure the DIP switches 101 and 102 as follows:

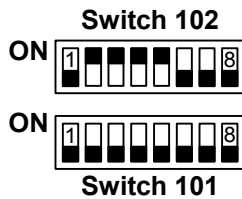

Additionally the termination can be activated by changing switch 1 of Switch 102 to ON.

### 5.2.5 USB Configuration

To select the USB interface, configure the DIP switches 101 and 102 as follows:

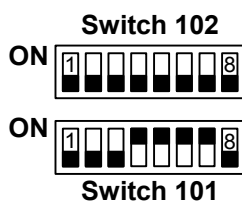

## 5.3 Interface address setting through DIP switches - not yet completed in firmware

Address setting is possible via TMCL.

DIP switch 100, switches 4 to 8 adjust the address of the CAN and RS-422 interfaces. Only one of these interfaces can be used at a time.

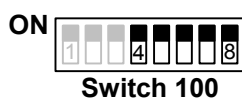

TBD

## 5.4 Software selection through DIP switches – not yet completed in firmware

The firmware loaded into the TMCM-102 is always active. Only one firmware can be loaded at a time. The setting of DIP switch 100, switches 2 and 3 selects which software to be used, either TMCL, CANopen or IMS\_clone.

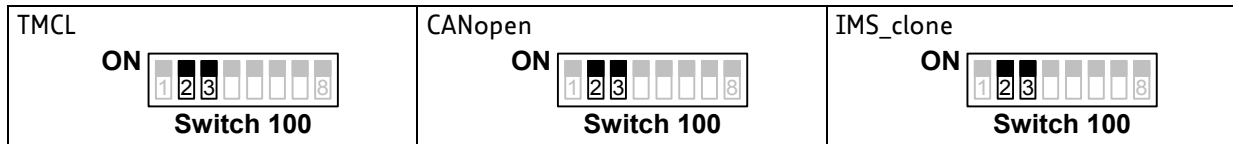

TBD

## 5.5 IN8 setting by DIP switch

The input IN8 on pin 11 of connector 3 can be set by switch 1 of Switch 100. Additionally the +5V optocoupler supply on the terminal connector pin 14 has to be connected. The +5V output on pin 5 can be used. Switching to ON pulls IN8 to ground. The IN8 input of the TMCM-102 Base board is low active.

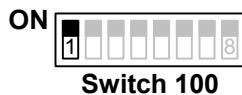

## 5.6 Encoder connection

The TMCM-102 Add-on-board provides a single ended encoder interface. Use the encoder entrances ENC\_A+ for A (Terminal pole 4), ENC\_B+ for B (pole 3) and ENC\_N+ for N (pole 2). The +5V DC supply voltage (pole 5) can be used for the encoder. For greater orders differential encoders can be supported on request, also.

## 5.7 Reference switches

Two digital reference / stop switch inputs are provided (LIMIT B = stop left and LIMIT A = stop right). They are used as an absolute position reference for homing and to set a hardware limit for the motion range. The inputs are optically isolated, active low and use TTL levels.

## 5.8 LEDs

LED	Labeled	Function
ERROR	D100	Indicating driver fault condition, low active
OUT3	D101	User controlled output #3 indicator, high active
OUT1	D102	User controlled output #1 indicator, high active
OUT2	D103	User controlled output #2 indicator, high active

Table 5.1: LEDs

## 6 Revision History

### 6.1 Documentation Revision

Version	Comment	Author	Description
0.90	11-Oct-2006	HC	Initial Version
0.91	9-Feb-2007	HC	Update to hardware version 1.1
0.92	2-Apr-2007	GE	Several corrections / updates
1.00	13-June-2007	HC	Pinning of connector 1 corrected

Table 6.1: Documentation Revisions

### 6.2 Firmware Revision

Version	Comment	Description
3.24	Initial Release	Please refer to TMCL documentation

Table 6.2: Firmware Revisions

## 7 References

- [TMCL]                                    TMCL manual (see <http://www.trinamic.com>)  
 [TMC-102]                                TMC-102 manual (see <http://www.trinamic.com>)