

PD-163-42 and TMCM-163

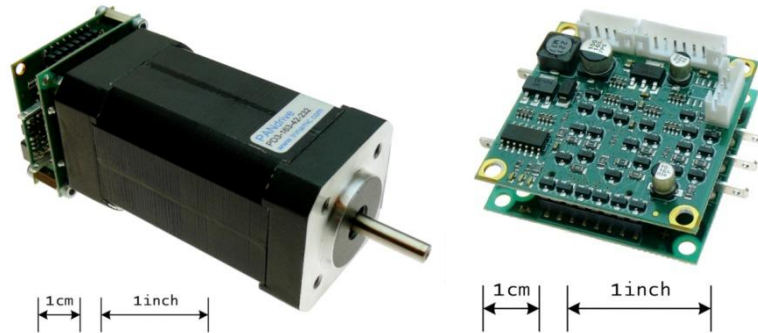

Hardware Manual

V1.04
2009-JUN-10



TRINAMIC
MOTION CONTROL

Trinamic Motion Control GmbH & Co. KG
Sternstraße 67
D - 20357 Hamburg, Germany
<http://www.trinamic.com>

Table of Contents

1	Life support policy.....	4
2	Features.....	5
3	Order codes.....	6
4	Electrical and mechanical interfacing.....	7
4.1	Connector location.....	7
4.1.1	Connector location on the controller board (top).....	7
4.1.2	Connector location on the power board (bottom).....	7
4.2	Connector pin assignment.....	8
4.2.1	Connectors on the controller board (top).....	8
4.2.2	Connectors on the power board (bottom).....	9
4.3	Dimensions.....	10
4.3.1	Dimensions of TMC-163.....	10
4.3.2	Dimensions of PD-163-42.....	11
4.4	PANdrive™ specifications.....	12
4.4.1	PANdrive™ motor.....	12
5	Functional description.....	15
5.1	Options for stand-alone operation.....	15
5.2	Temperature, current and voltage monitoring function.....	16
5.3	Under voltage behavior.....	16
5.4	Demonstration software.....	16
5.5	Programmable motor current limit.....	16
5.6	Parameterizing the PID velocity regulator.....	17
5.7	Parameterizing the positioning algorithm.....	19
5.8	Restoring factory default settings.....	19
6	Operational and limiting ratings.....	20
7	Revision history.....	21
7.1	Document revision.....	21
7.2	Firmware revision.....	21
7.3	Hardware revision.....	21
8	References.....	22

Table of tables

Table 3.1:	Order codes.....	6
Table 4.1:	Interface connector.....	8
Table 4.2:	Hall sensor connector.....	8
Table 4.3:	I/O connector.....	8
Table 4.4:	Motor and power supply connectors.....	9
Table 4.5:	Motor specifications.....	12
Table 5.1:	Options for stand-alone operation.....	15
Table 5.2:	Temperature, current and voltage monitoring function.....	16
Table 5.3:	PID default values.....	18
Table 6.1:	Operational and limiting ratings.....	20
Table 7.1:	Documentation revision.....	21
Table 7.2:	Firmware revision.....	21
Table 7.3:	Hardware revision.....	21

Table of figures

Figure 4.1: Pinning of the controller board	7
Figure 4.2: Pinning of the power board	7
Figure 4.3: Dimensions of the controller board (all values in mm)	10
Figure 4.4: Dimensions of the power board (all values in mm)	10
Figure 4.5: Dimensions of PD-163-42 (all values in mm)	11
Figure 4.6: QBL4208-81-04-019 velocity vs. torque characteristics	13
Figure 4.7: QBL4208-100-04-025 velocity vs. torque characteristics	14
Figure 4.8: QBL4208-100-04-025 torque vs. current	14
Figure 5.1: Main parts of the PDx-163-42	15
Figure 5.2: LED positions	16
Figure 5.3: PID velocity regulator parameters	18
Figure 5.4: Parameterizing the positioning algorithm	19

1 Life support policy

TRINAMIC Motion Control GmbH & Co. KG does not authorize or warrant any of its products for use in life support systems, without the specific written consent of TRINAMIC Motion Control GmbH & Co. KG.

Life support systems are equipment intended to support or sustain life, and whose failure to perform, when properly used in accordance with instructions provided, can be reasonably expected to result in personal injury or death.

© TRINAMIC Motion Control GmbH & Co. KG 2005

Information given in this data sheet is believed to be accurate and reliable. However neither responsibility is assumed for the consequences of its use nor for any infringement of patents or other rights of third parties, which may result from its use.

Specifications are subject to change without notice.

2 Features

The PDx-163-42 is a full mechatronic solution including a 42mm brushless DC motor (NEMA 17). It combines a BLDC controller/driver electronic module (TMC-163-42) with a range of different motor types with internal HALL sensors.

The TMC-163 is a controller/driver module for general Brushless DC motor applications. It integrates velocity and torque control as well as a hall sensor based positioning mode. The position resolution depends on the motor, i.e. an 8 pole motor as integrated in the PDx-163-42 leads to a motor axis resolution of 30 degrees. The module can be used in stand-alone operation or remote controlled via RS232 or RS485 interface (ordering option). The small size of the unit (43mm x 43mm x 20mm) allows mounting directly on the motor.

The software command set and protocol compatibility with the TRINAMIC family of stepper motor controllers makes it easy to choose either a stepper motor or a BLDC motor or any combination for an application.

Applications

- Constant velocity and torque limited drives
- Positioning applications with automatic ramp generation
- Remote controlled (RS232 or RS485) or stand-alone operation (0 - 10V signal)
- Mount directly on motor or in motor cabling box (Size: 43 x 43 x 20 mm³)
- Pluggable connectors for interface

Motor type

- Block commutated 3 phase BLDC motors with hall sensors
- Motor power from a few watt to 360W
- Motor velocity up-to 100,000 RPM (electrical field)
- 14 to 36V nominal motor voltage (or any value in between)
- Coil current up-to 10A nominal (up-to 13A current for a short time)

Highlights

- High efficiency operation, low power dissipation
- Typical supply voltage 14V - 36V
- Integrated protection: reverse polarity, overload, and overtemperature
- Supports the TRINAMIC TMCL™ protocol and the TMCL™ software environment for parameterizing
- On the fly alteration of motion parameters (e.g. position, velocity, acceleration)

Other

- ROHS compliant

3 Order codes

Order code	Description	Dimensions
TMCM-163 (-option)	BLDC module	43 x 43 x 20 mm ³
TMCM-163-CABLE	Cable loom for TMCM-163 (three cables)	20 cm
PD3-163-42 (-option)	PANdrive™ (TMCM-163 with QBL-4208-81-04-019)	43 x 43 x 106.5 (+19) mm ³
PD4-163-42 (-option)	PANdrive™ (TMCM-163 with QBL-4208-100-04-025)	43 x 43 x 125.5 (+19) mm ³
Option	Host interface	
232	RS232 interface	
485	RS485 interface	

Table 3.1: Order codes

4 Electrical and mechanical interfacing

4.1 Connector location

4.1.1 Connector location on the controller board (top)

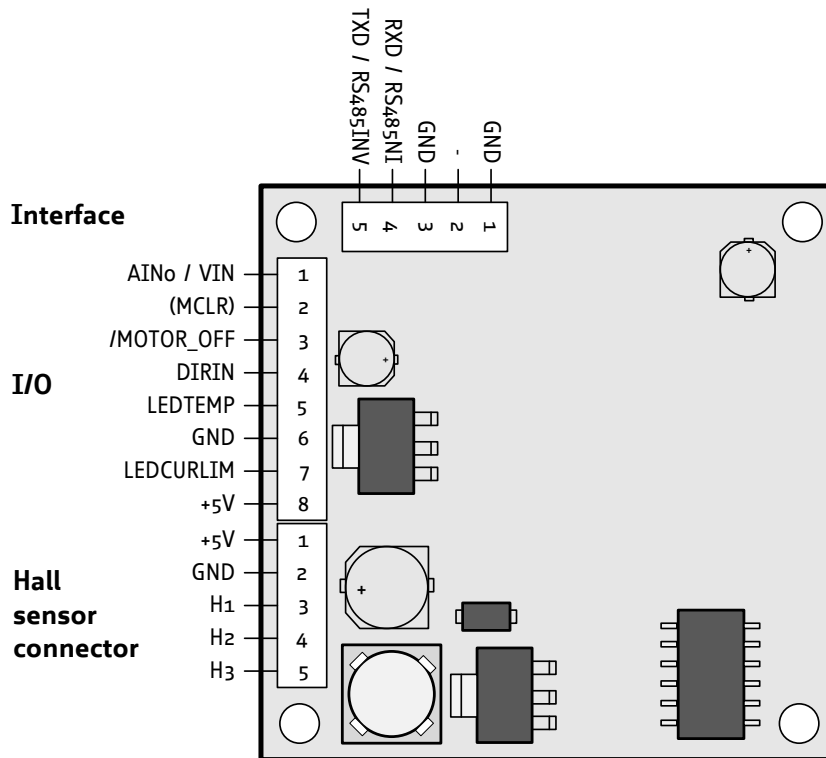

Figure 4.1: Connectors (controller board)

4.1.2 Connector location on the power board (bottom)

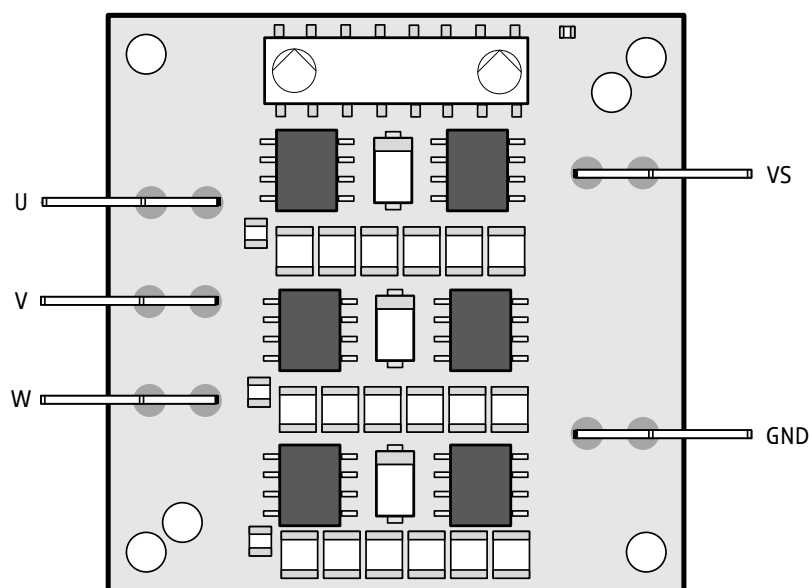

Figure 4.2: Connectors (power board)

4.2 Connector pin assignment

4.2.1 Connectors on the controller board (top)

Interface: 5 pin, 2mm JST PH series: B5B-PH-K, mating connector: PHR-5
(assembly option: 1.5mm JST type S5B-ZR-SM2-TF)

Hall sensor: 5 pin, 2mm JST PH series: B5B-PH-K, mating connector: PHR-5

Additional I/Os: 8 pin, 2mm JST PH series: B8B-PH-K, mating connector: PHR-8

4.2.1.1 Interface connector

Pin	Name	Function
1	GND	Ground
2	-	-
3	GND	Ground
4	RXD/ RS485 NI	RXD signal of module for RS232 communication (RS232 version) Non-inverting RS485 signal (RS485 version)
5	TXD/ RS485 INV	TXD signal of module for RS232 communication (RS232 version) Inverting RS485 signal (RS485 version)

Table 4.1: Interface connector

4.2.1.2 Hall sensor connector

Pin	Name	Function
1	+5V	5V supply for motor hall sensors and as reference for external purpose
2	GND	Ground
3	H1	Hall sensor signals (5V TTL input) <i>10K pull-up resistors (5V) might be required depending on motor type! They are not included in the actual version.</i>
4	H2	
5	H3	

Table 4.2: Hall sensor connector

4.2.1.3 I/O connector

Pin	Name	Function
1	AINo / VIN	Analogue input. Used for velocity control in stand-alone operation by supplying external 0 - 10V signal
2	(MCLR)	
3	/MOTOR_OFF	Emergency stop. Tie this pin to GND to stop the motor. The motor can be restarted via the interface or by cycling the power supply.
4	DIRIN	5V TTL input. Tie to GND to inverse motor direction, leave open or tie to 5V otherwise.
5	LEDTEMP	CMOS Output for overtemperature indication
6	GND	Ground
7	LEDCURLIM	CMOS Output for current limiting indication
8	+5V	5V supply for motor hall sensors and as reference for external purpose

Table 4.3: I/O connector

4.2.2 Connectors on the power board (bottom)

Please plug the power supply and motor cables laterally with blade connectors.

Name	Function
U	BLDC motor driver outputs
V	
W	
VS	Positive power supply voltage
GND	Ground

Table 4.4: Motor and power supply connectors

4.3 Dimensions

4.3.1 Dimensions of TMCM-163

The entire board of the TMCM-163 measures 43 x 53.5 x 20 mm. The module has four 3.0 mm diameter mounting holes in a 53 mm diameter square order. The two additional mounting holes (for the motor) on the power board have the same size. They are in a 43.5 mm diameter square order. Please take M3 screws for mounting. There is 10.5 mm space between the upper and the lower board.

4.3.1.1 The controller board on top

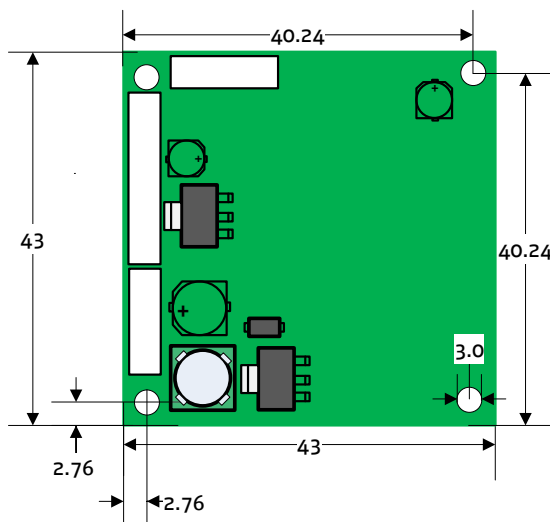

Figure 4.3: Dimensions of the controller board (all values in mm)

4.3.1.2 The power board

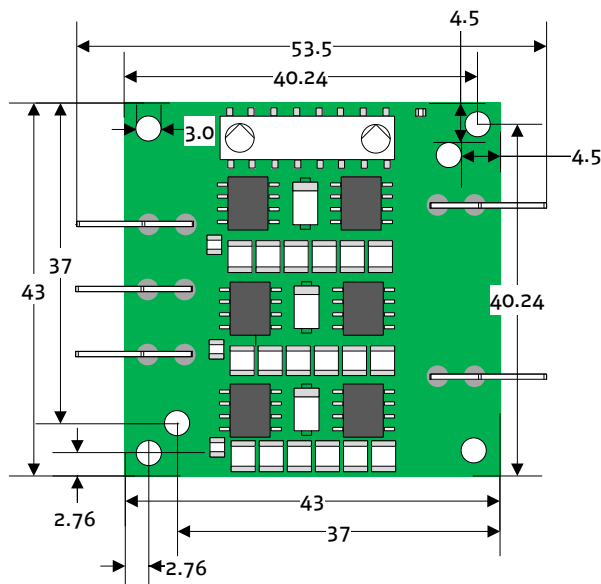

Figure 4.4: Dimensions of the power board (all values in mm)

Please note, that the controller board and the power board have the same length and width without connectors. The mounting holes in the angles are identical too, but the board on top does not have the additional two mounting holes for the motor.

4.3.2 Dimensions of PD-163-42

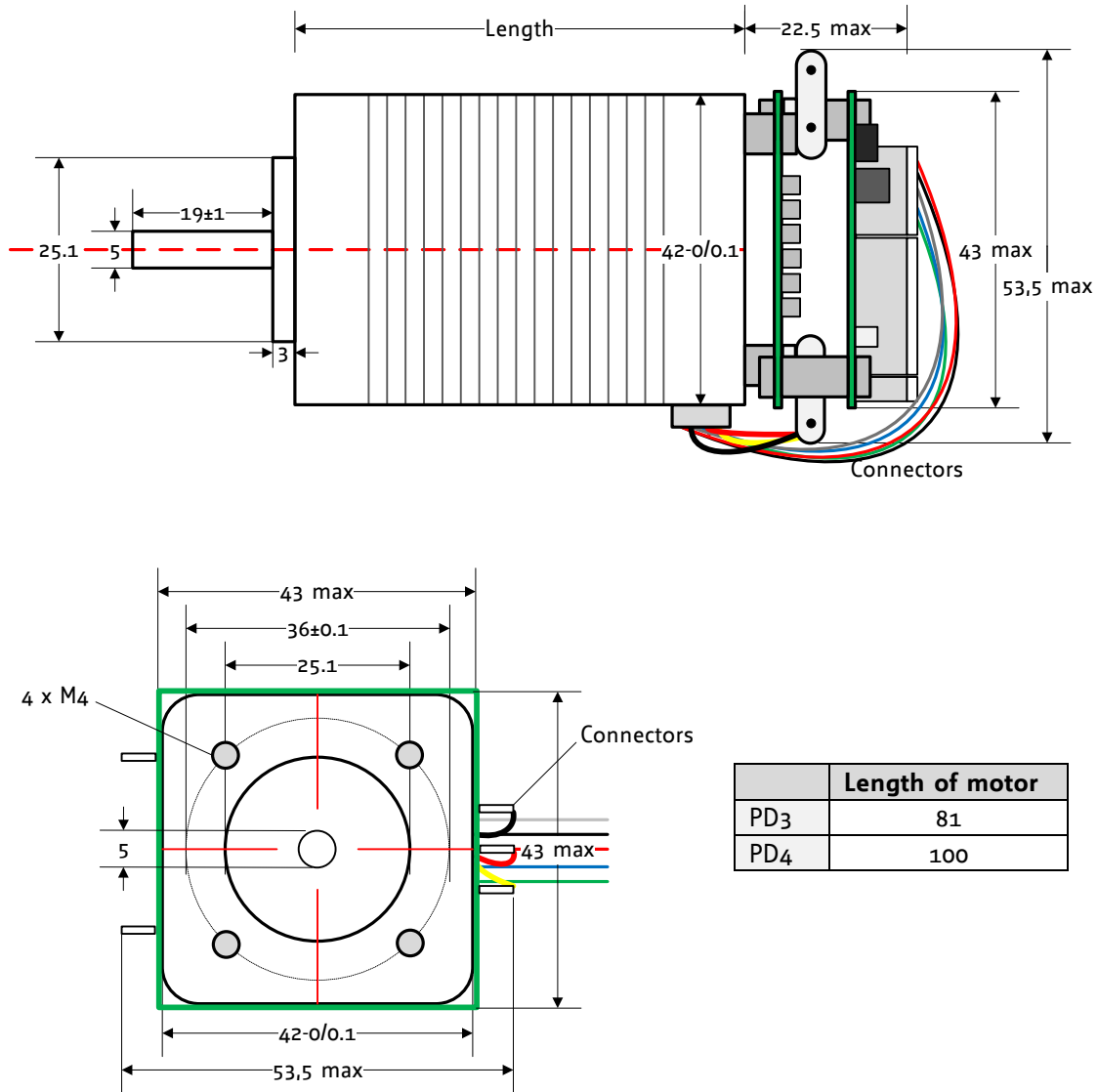

Figure 4.5: Dimensions of PD-163-42 (all values in mm)

4.4 PANdrive™ specifications

This chapter describes the additional components of the PD-163-42.

4.4.1 PANdrive™ motor

The PDx-163-42 includes a 42 mm brushless DC motor (NEMA 17). Our QMOT BLDC motors are excellent motors for universal use. They feature a long life with high quality ball bearings and no abrasion. These BLDC motors give a good fit to the TRINAMIC family of medium and high current BLDC motor modules like the TMC-163.

Main characteristics:

Hall Effect Angle:	120° electric angle
Shaft run out:	0.025 mm
Insulation Class:	B
Radial Play:	0.02 mm 450G load
Max Radial Force:	28N (10 mm from flange)
Max Axial Force:	10N
Dielectric Strength:	500 VDC for one minute
Insulation Resistance:	100M Ohm min. 500VDC
Recommended Amb. Temp.:	-20 to +40°C
Bearing:	Brushless motors fitted with ball bearings

Specifications		QBL 4208	
		-81-04-019	-100-04-025
No. of Pole		8	8
No. of Phase		3	3
Rated Voltage	V	24	24
Rated Phase Current	A	5.14	6.95
Rated Speed	RPM	4000	4000
Rated Torque	Nm	0.185	0.25
Max Peak Torque	Nm	0.56	0.75
Torque Constant	Nm/A	0.036	0.036
Line to Line Resistance	Ω	0.55	0.28
Line to Line Inductance	mH	0.8	0.54
Max Peak Current	A	15.5	20
Length (L _{MAX})	mm	81	100
Rotor Inertia	kgm ² x 10 ⁻⁶	72	96
Mass	kg	0.65	0.8
Related Trinamic PANdrive™		PD3-163-42	PD4-163-42

Table 4.5: Motor specifications

4.4.1.1 QBL4208-81-04-019

This diagram shows the velocity vs. torque with 24V supply voltage:

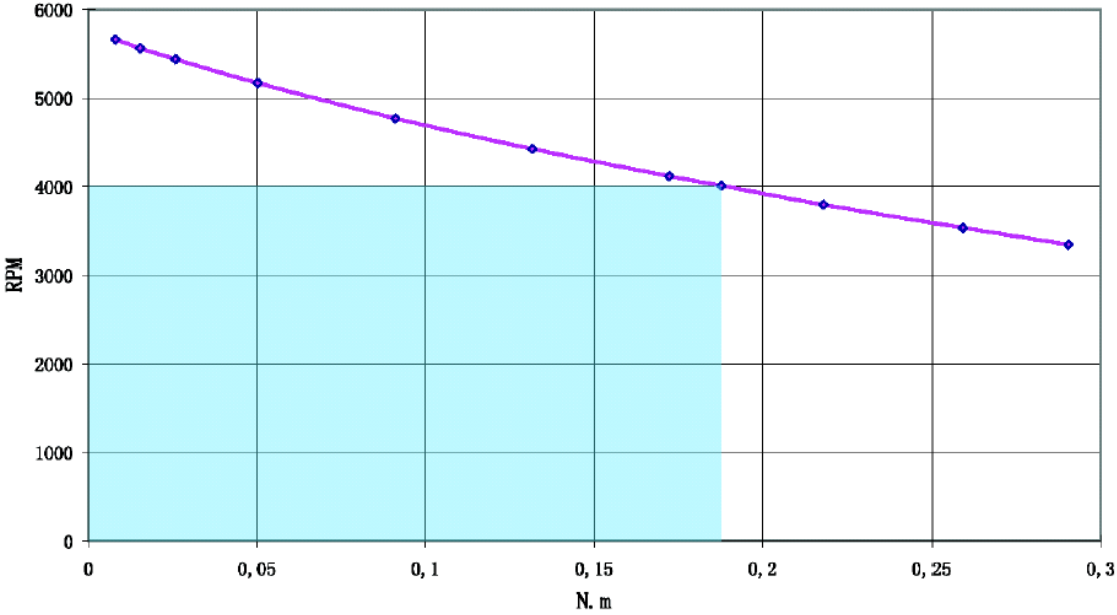

Figure 4.6: QBL4208-81-04-019 velocity vs. torque characteristics

4.4.1.2 QBL4208-100-04-025

This diagram shows the velocity vs. torque with 24V supply voltage:

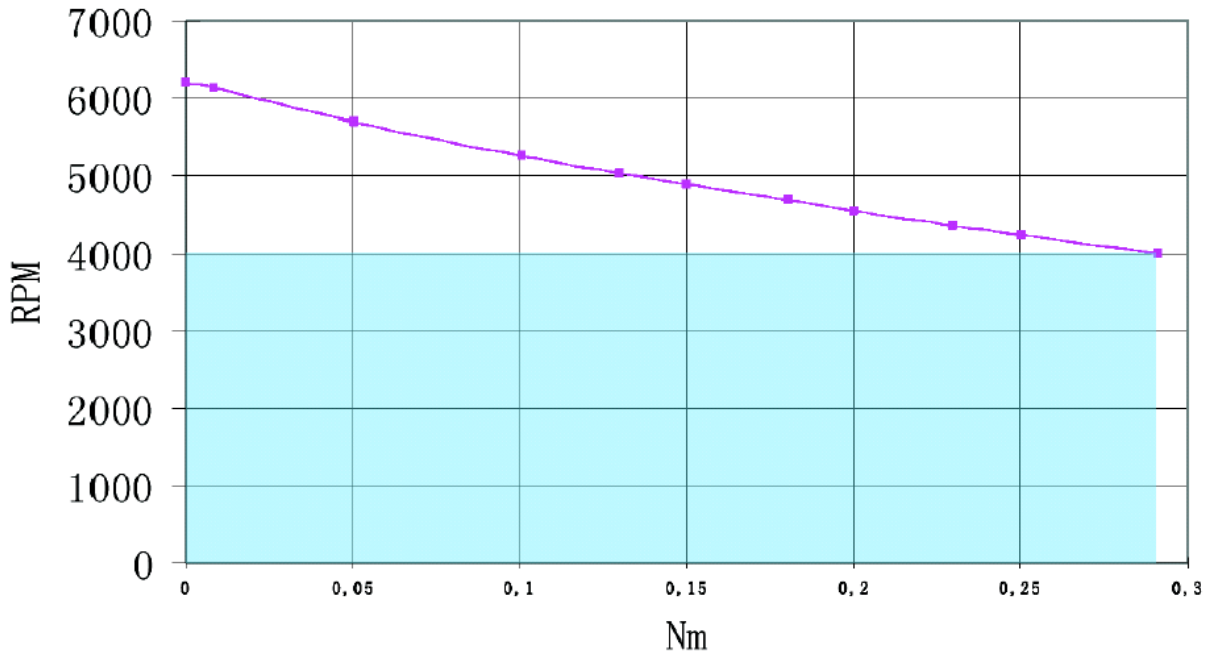

Figure 4.7: QBL4208-100-04-025 velocity vs. torque characteristics

This diagram shows torque vs. current:

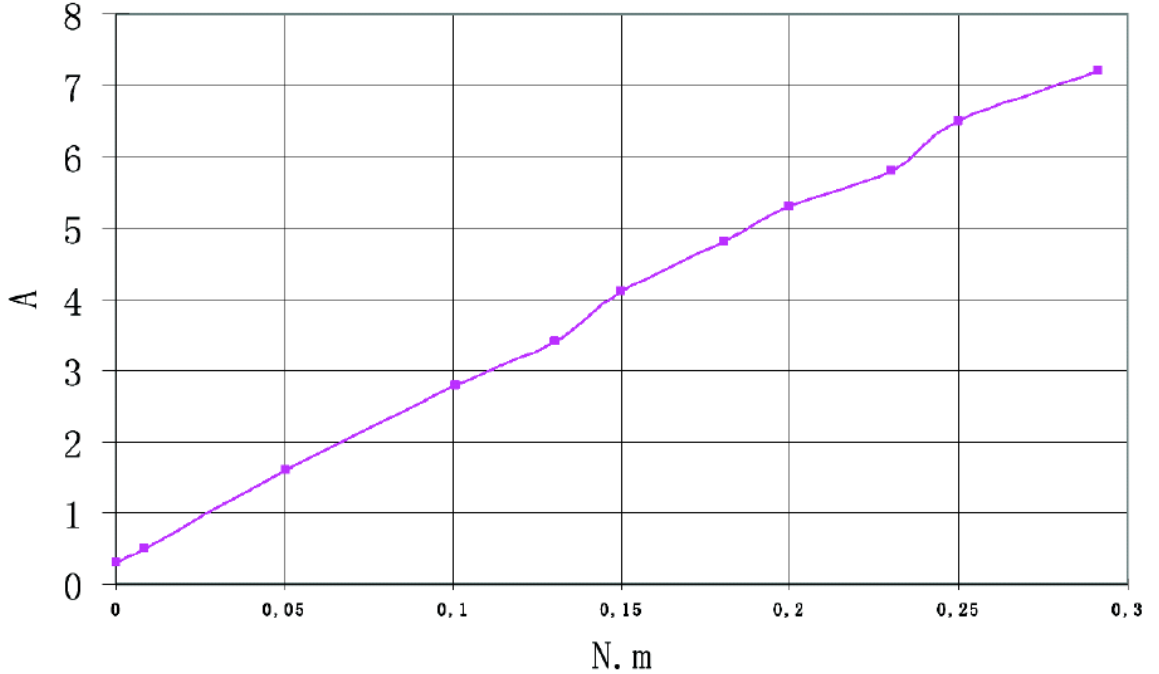

Figure 4.8: QBL4208-100-04-025 torque vs. current

5 Functional description

The PD-163-42 is a full mechatronic solution including a 42 mm brushless DC motor (NEMA 17). It combines the convenient BLDC controller/driver electronic TMC163-42 with a range of different motor types with internal HALL sensor. The PD-163-42 offers two motor torque options and can be controlled via RS232 or RS485 interface. Power supply and motor coils are connected with blade terminals. The communication interface and the multi-purpose I/Os can be connected via high density JST connectors. It integrates a PID-regulator for velocity control. The module supports positioning based on the motors hall sensor information.

The TMC163 module can be remote controlled with the PC demonstration software or with a user specific program. Furthermore, it can be controlled by an analog voltage (stand-alone mode). You can modify the stand-alone mode by writing initialization values on the on-board EEPROM, e.g. a maximum rotation velocity, motor current limit and rotation direction. Please refer to the TCM BLDC Reference and Programming Manual for detailed software information.

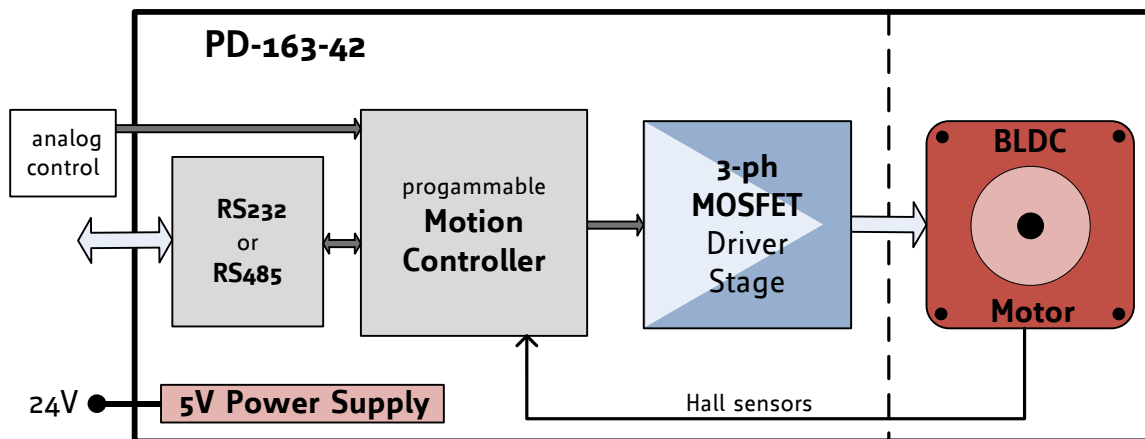

Figure 5.1: Main parts of the PDx-163-42

5.1 Options for stand-alone operation

Mode	Functionality	Software settings
PWM control	Motor PWM controlled by the analog input VIN. Motor direction controlled by DIR in pin.	Remote control flag = 0 Power on velocity = 0
PID enforced velocity	Maximum motor velocity v_{\max} set via software. This velocity is scaled by VIN pin voltage and enforced by the PID velocity regulator.	Remote control flag = 0 Power on velocity = v_{\max}
Constant velocity	Desired motor velocity v set via software	Remote control flag = 1 Power on velocity = v

Table 5.1: Options for stand-alone operation

In all modes, the motor torque is limited by the maximum current setting. The polarity of the DIR pin can be inversed by the direction input reverse flag setting.

5.2 Temperature, current and voltage monitoring function

LED positions of the TMCM-163-42:

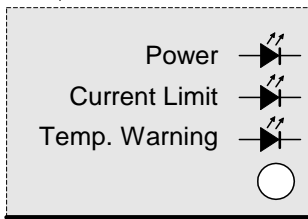

Figure 5.2: LED positions

LED/Output	Action	Meaning
Power		
Current Limit	Blink	The current limit LED blinks upon under voltage switch off
	On/Flicker	Motor PWM is reduced due to exceeding the set motor current limit
Temperature Warning	Blink	The power stage on the module has exceeded a critical temperature of 100°C (prewarning).
	On	The power stage on the module has exceeded a critical temperature of 125°C. The motor becomes switched off, until temperature falls below 115°C. The measurement is correct to about +/-10°C

Table 5.2: Temperature, current and voltage monitoring function

5.3 Under voltage behavior

- The motor is switched on, if the supply voltage exceeds 9.0V
- The motor is switched off, if the supply voltage falls below 8.5V
- At supply voltages below 12V, maximum motor current linearly decreases down to about 0.7A at 9V. To be sure to be outside this area, use at least 13V supply voltage, due to voltage drop in the reverse polarity protection.
- If the motor load is too high, the module switches off (under voltage switch off). The reason for this is the reverse polarity protection
- The motor current is limited at low supply voltages: 0.5A at 9V, linear increasing to 4A at 12V. To be sure to be outside this field, use 13V supply voltage
- The current reduction due to the low supply voltage may inhibit the starting-up of the motor

5.4 Demonstration software

You can set the TMCM-163 into operation with the demonstration software for basic control and diagnostics. Please use the TRINAMIC TMCL-IDE to update the modules firmware and to test/set all of the modules' parameters. If your motor shows an instable behavior, you have to tune the PID regulator values. In order to do this, you need to use the TMCL-IDE, too.

5.5 Programmable motor current limit

The motor current limiting function is meant as a function for torque limiting and for protection of the motor, the power supply, and the mechanics.

Whenever the pre-programmed motor current is exceeded in a chopper cycle, the TMC163 calculates a reduced PWM value for the next chopper cycle. New values are calculated 100 times a second. The response time of the current regulation can be set using the parameter "current regulation loop delay":

The value zero means, that in every 100Hz period, the current correction calculation is directly executed and the resulting PWM value is taken. A higher current loop delay acts like a filter for the current. The higher the delay values the slower the current loop response time. The value 5 (default) leads to a current regulation response time of about 60ms. On the mechanical side, a higher value simulates a higher dynamic mass of the motor.

$$t_{LIM} = \frac{1}{\frac{1}{3s} + \frac{1}{10ms \cdot (1 + x_{CRLD})}}$$

x_{CRLD} is the current regulation loop delay parameter, t_{LIM} the resulting time for a $1/e$ response.

The actual current regulation time may be faster, depending on the PID settings.

Attention: Please be careful, when programming a high value into the current regulation loop delay register or if you want to work above the modules' rated motor current: The motor current could reach a very high peak value upon mechanical blocking of the motor. If the short time current is not limited to a maximum of about 30A, this could destroy the unit.

- The current measurement cannot detect currents below about 200-300mA. If the current limit is set to a value, which is too low, the motor may become continuously switched off.
- The current limiting function is not meant as a protection against a hard short circuit.
- The maximum motor current should never be set above the rated short time motor current, because the current regulator cannot operate correctly, if the current limit is set too close to the measurement range limits.

5.6 Parameterizing the PID velocity regulator

The motion control commands (TMCL_ROL, TCMC_ROR, and TMCL_MVP) use a PID regulator for velocity control. The PID regulator has to be parameterized with respect to a given motor in a given application. The default parameter set of the PID regulator covers a range of motors suitable for the TMC163 module and typically works stable up to 15000 rpm maximum motor velocity. However, for slower motors, the response time with this parameter set may become quite slow.

The PID regulator uses four basic parameters: The P , I and D values, as well as a timing control value. The timing control value (PID regulation loop delay) determines, how often the PID regulator is evoked. It is given in multiple of 10ms:

$$t_{PIDDELAY} = x_{PIDRLD} * 10ms$$

x_{PIDRLD} is the PID regulation loop delay parameter; $t_{PIDDELAY}$ is the resulting delay between two PID calculations

The PID parameters are divisors, e.g. use a higher value, to get less influence from the parameter. To parameterize for a given motor, first modify the P parameter, starting from a high value and going to a lower value, until the fastest response with a minimum oscillation is given.

After that, do the same with the parameter I . Now, modify the D parameter in the same way. It will damp part of the oscillations of the other parameters, too.

As a rule of thumb, you can set the P parameter at a starting value, for example:

$$P\text{-param} = (\text{Maximum actual RPM of the motor at 100\% PWM}) * 0.15$$

The module uses the internally calculated velocity value (1/4 of electrical RPM value) as input into the PID regulator.

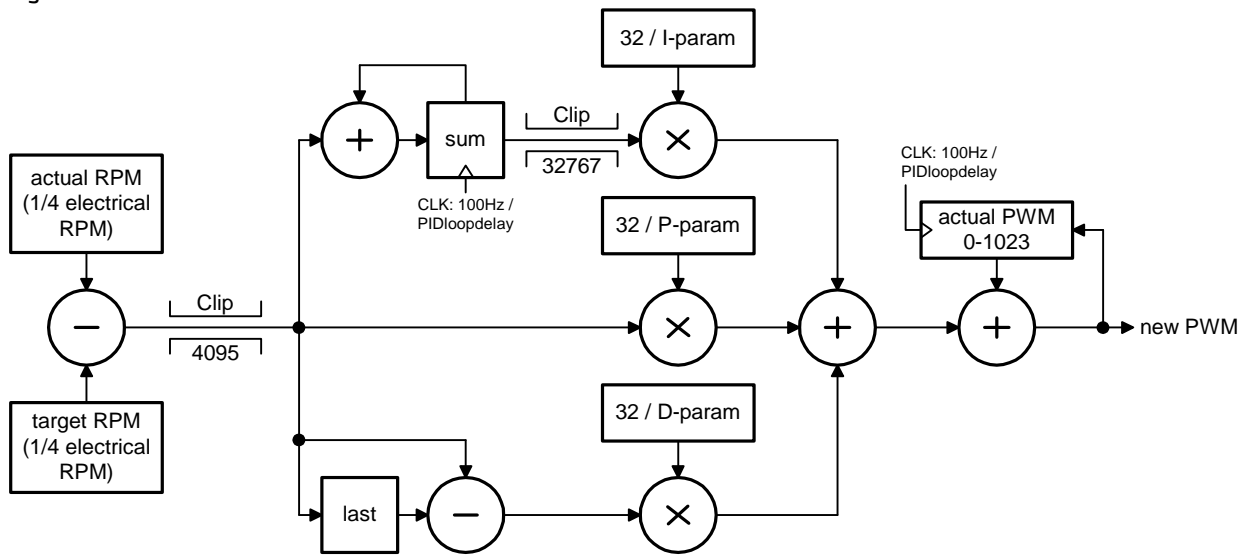

Figure 5.3: PID velocity regulator parameters

Parameter	Default values
P-param	2400
I-Param	150
D-Param	600
X _{PIDRLD}	2

Table 5.3: PID default values

5.7 Parameterizing the positioning algorithm

The module supports a positioning based on the motor's hall sensor information. Please refer to the schematic for the required set of parameters.

You can optimize the parameter set in your application to get a good positioning accuracy and a fast positioning speed:

1. Select the maximum positioning speed as desired.
2. Choose a minimum positioning speed, which allows a fast stop of the motor.
3. Set the MVP_slow_down_distance in a way, which the motor slows down to the min_pos_speed in this area (dotted line).
4. Choose the active brake velocity as allowable for your application.
5. Set MVP_target_reached_distance to the value, which gives a stop as near as possible to the target position.

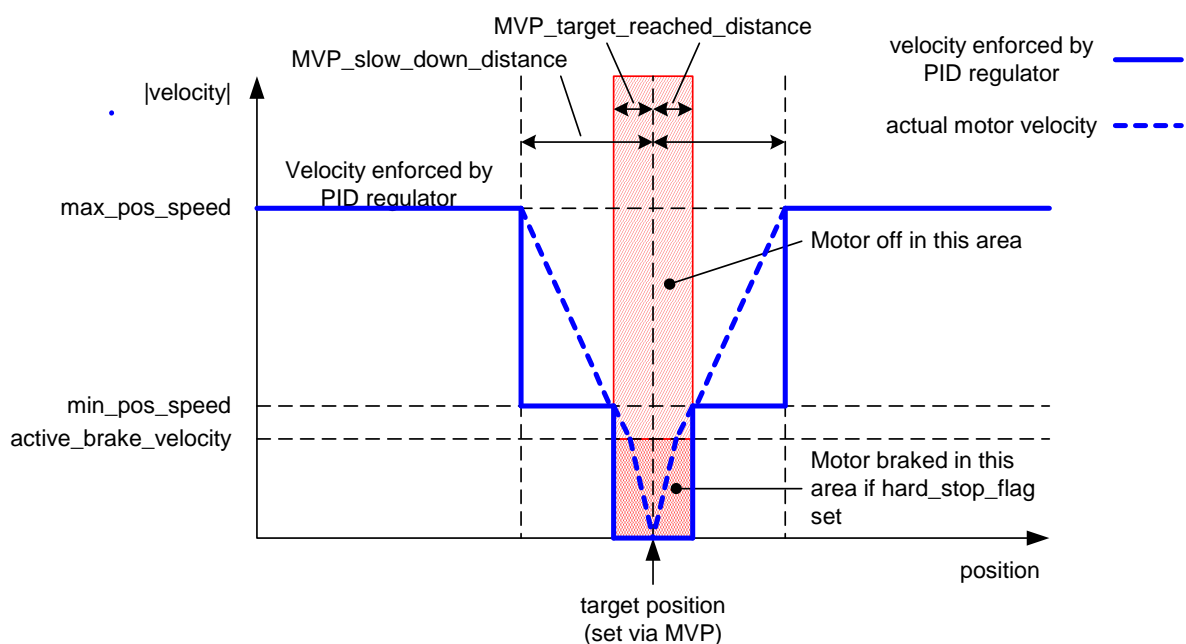

Figure 5.4: Parameterizing the positioning algorithm

5.8 Restoring factory default settings

The module stores user settings in an on-board EEPROM. You can restore the factory values by setting and storing a 255 to the current limit parameter. Upon the next power on, all EEPROM values are loaded with the default settings. However, this also clears the temperature measurement calibration, which should be recalibrated before operating the device near its temperature limits.

6 Operational and limiting ratings

The operational ratings show the intended range of values and should be used for the design. An operation within the limiting values is possible, but not for extended periods, because the unit life time may be shortened. In no case shall the limiting values be exceeded.

Symbol	Parameter	Min	Type	Max	Unit
V_S	Power supply voltage for operation	9.0*)	14 - 36	37.0	V
I_S	Power supply current	0.04		I_{MOT}	A
P_{ID}	Module idle power consumption		1.2		W
V_5	5 Volt (+8%) output external load (hall sensors plus other load)			40	mA
I_{MC}	Continuous motor current at V_{MF}		0 - 10	10	A
I_{MP}	Short time motor current in acceleration periods It is not recommended to set motor current above 10A!			13	A
I_{MPP}	Peak coil output current for 100ms			30	A
V_I	Logic input voltage on digital/hall sensor inputs	-0.3		$V_{CC}+$ 0.3	V
V_O	Logic output current on digital outputs (5V CMOS output)			10	mA
V_{IA}	Analog input voltage	-24	0 - 10	24	V
f_{CHOP}	Chopper frequency		20		kHz
E_X	Exactness of voltage and current measurement	-8		+8	%
T_{SL}	Motor output slope (U, V, W)		100		ns
T_O	Environment temperature operating	-25		+85	°C
T_{OF}	Environment temperature for operation at full specified current (air flow might be required, depending upon supply voltage)	-25		+60	°C
T_{board}	Temperature of the module, as measured by the integrated sensor.		<100	125	°C

Table 6.1: Operational and limiting ratings

*) At supply voltages below 12V, maximum motor current linearly decreases down to about 0.7A at 9V. To be sure to be outside this area, use at least 13V supply voltage, due to voltage drop in the reverse polarity protection.

Note:

The power supply should be designed in a way, that it supplies the nominal motor voltage at the desired maximum motor current. In no case shall the supply value exceed the upper/lower voltage limit.

To be able to cope with voltage which might be fed back by the motor, the supply should provide a sufficient output capacitor. Additionally, a 39V suppressor (zener-) diode may be used.

7 Revision history

7.1 Document revision

Version	Date	Author	Description
1.00	2005-FEB-16	BD	Initial version
1.02	2006-MAY-12	HC	Order codes added, minor changes
1.03	2007-MAY-11	HC	Revised version, functional description (chapter 5) added
1.04	2009-JUN-10	SD	Information about PD-163-42 added

Table 7.1: Documentation revision

7.2 Firmware revision

Version	Date	Author	Description
1.01	2005-FEB-11	BD	Bug in current regulation algorithm: Instable operation with settings above 4.6A
1.02	2005-MAY-24	BD	Added baud rate switching Added RS485 interface, tacho output Fixed current regulation bug GPIO1 provides for a hall sensor derived tacho signal Analog control input now uses 10 bit resolution for PWM/velocity control
1.03	2005-MAY-27	BD	Added possibility for inversion for hall sensor signals Corrected velocity readout when motor is turned by external force
1.04	2005-OKT-11	BD	Added disable stop switch function
1.05	2006-MAR-13	BD	RS485 - sent back address corrected

Table 7.2: Firmware revision

7.3 Hardware revision

Version	Date	Description
1.00	2004-NOV-04	Initial version – Prototypes
1.10	2006-MAR-06	Series version
2.00	2007-DEC-20	Series version – improved temperature and supply voltage range, connectors added for power and motor phases

Table 7.3: Hardware revision

8 References

TMCL™
TMCL™ BLDC Module
QMot motors

TMCL™ manual, www.trinamic.com
Reference and programming manual, www.trinamic.com
QBL4208, www.trinamic.com