

V 1.50

HARDWARE MANUAL

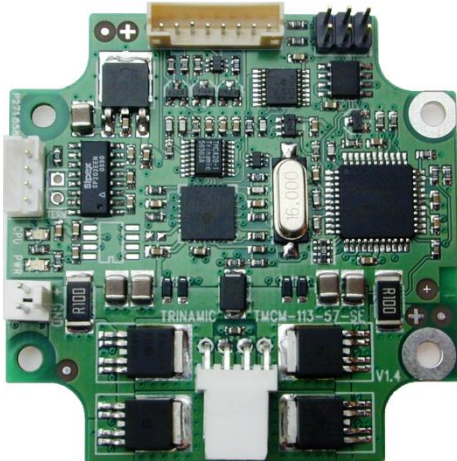

TMCM-113-60-SE

controller / driver
up to 2.8A RMS / 24V
RS232 or RS485
integrated sens0step™ encoder
chopSync™
stallGuard™

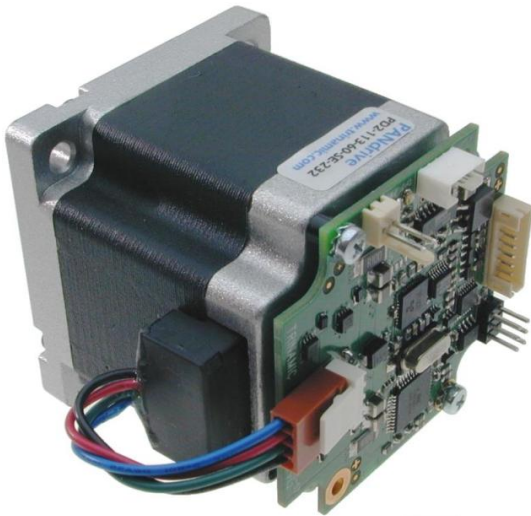

PDx-113-57/60-SE

full mechatronic device
up to 2.8A RMS / 24V
RS232 or RS485
integrated sens0step™ encoder
chopSync™
stallGuard™

TRINAMIC Motion Control GmbH & Co. KG
Hamburg, Germany

www.trinamic.com

Table of contents

1	Life support policy	3
2	Features	4
3	Order codes	5
4	Mechanical and electrical interfacing	6
4.1	Size of PDx-113-57-SE.....	6
4.2	Size of PDx-113-60-SE.....	7
4.3	Size of electronics	8
4.4	Motor.....	9
4.5	Connectors.....	10
4.5.1	Power connector.....	11
4.5.2	Serial communication connector	11
4.5.3	I/O connector.....	11
4.5.4	Motor connector.....	12
4.6	Serial communication interface.....	12
4.6.1	RS232.....	12
4.6.2	RS485.....	13
4.7	Reference switch inputs	15
4.8	General purpose inputs	15
4.9	General purpose outputs.....	16
5	Operational ratings	17
6	Functional description	19
7	Torque curves	20
7.1.1	PD1-113-57-SE.....	20
7.1.2	PD2-113-57-SE.....	20
7.1.3	PD3-113-57-SE.....	21
7.1.4	PD4-113-57-SE.....	21
7.1.5	PD1-113-60-SE.....	22
7.1.6	PD2-113-60-SE.....	22
7.1.7	PD3-113-60-SE.....	23
7.1.8	PD4-113-60-SE.....	23
8	Revision history	24
8.1	Document revision	24
8.2	Hardware revision	24
9	References.....	25

1 Life support policy

TRINAMIC Motion Control GmbH & Co. KG does not authorize or warrant any of its products for use in life support systems, without the specific written consent of TRINAMIC Motion Control GmbH & Co. KG.

Life support systems are equipment intended to support or sustain life, and whose failure to perform, when properly used in accordance with instructions provided, can be reasonably expected to result in personal injury or death.

© TRINAMIC Motion Control GmbH & Co. KG 2011

Information given in this data sheet is believed to be accurate and reliable. However neither responsibility is assumed for the consequences of its use nor for any infringement of patents or other rights of third parties, which may result from its use.

Specifications are subject to change without notice.



2 Features

The PDx-113-57/60-SE is a full mechatronic device consisting of a NEMA 23 (flange size 57mm) or NEMA 24 (flange size 60mm) stepper motor, controller/driver electronics and integrated encoder. The electronics itself is also available without the motor as TCM-113-60-SE module.

Applications

- Compact single-axis stepper motor solutions
- Encoder feedback for high reliability operation (-SE option)

Electrical data

- Supply voltage: +24V DC nominal (+7V... +28.5V DC)
- Motor current: up to 2.8A RMS (programmable)

Integrated motor (for PDx-113-57/60-SE only)

- Two phase bipolar stepper motor with 2.8A RMS nom. coil current
- Holding torque with 57mm motor: 0.55Nm, 1.01Nm, 1.26Nm or 1.89Nm
- Holding torque with 60mm motor: 1.1Nm, 1.65Nm, 2.1Nm or 3.1Nm

Integrated encoder (for -SE option only)

- Integrated sensOstep™ magnetic encoder (max. 256 increments per rotation) for step-loss detection under all operating conditions

Integrated motion controller

- Motion profile calculation in real-time (TMC428/429 motion controller)
- On the fly alteration of motor parameters (e.g. position, velocity, acceleration)

Integrated bipolar stepper motor driver

- Up to 16 microsteps per full step
- High-efficient operation, low power dissipation (TMC249 stepper driver with external MOSFETs)
- Dynamic current control
- Integrated protection
- Integrated stallGuard™ for motor stall detection (e.g. elimination of end switches)
- Integrated chopSync™ for high velocity operation

Interfaces

- inputs for reference switches, 2 general purpose inputs and 2 general purpose outputs
- either RS232 or RS485 serial communication interfaces

Software

- Available with TMCL™ (both interface options)
- stand-alone operation or remote controlled operation
- program memory (non volatile) for up to 2048 TMCL commands
- PC-based application development software TMCL-IDE available for free

Please see separate TMCL™ Firmware Manual for additional information

3 Order codes

The PDx-113-57/60-SE is currently available with two different stepper motor series (NEMA23 / 57mm flange size or) with four stepper motors of different length and holding torque each and two interface options:

With NEMA 23 / 57mm flange size motor:

Order code	Description	Length of unit
PD1-113-57-SE-option	PANdrive with 0.55Nm max./holding torque	60mm
PD2-113-57-SE-option	PANdrive with 1.01Nm max./holding torque	70mm
PD3-113-57-SE-option	PANdrive with 1.26Nm max./holding torque	75mm
PD4-113-57-SE-option	PANdrive with 1.89Nm max./holding torque	95mm

Table 3.1: Order codes (PDx-113-57-SE)

With NEMA 24 / 60mm flange size motor:

Order code	Description	Length of unit
PD1-113-60-SE-option	PANdrive with 1.10Nm max./holding torque	64mm
PD2-113-60-SE-option	PANdrive with 1.65Nm max./holding torque	75mm
PD3-113-60-SE-option	PANdrive with 2.10Nm max./holding torque	84mm
PD4-113-60-SE-option	PANdrive with 3.10Nm max./holding torque	105mm

Table 3.2: Order codes (PDx-113-60-SE)

The electronic module TCM-113-60-SE itself is also available with two serial interface options:

Order code	Description	Size of unit
TCM-113-60-SE-option	Single axis bipolar stepper motor controller / driver electronics with integrated encoder electronics	board size: 60mm x 60mm

Table 3.3: Order codes (TCM-113-60-SE)

Serial interface options:

Interface option	Communication interface
232	RS232 interface
485	RS485 interface

Table 3.4: Options

For cost critical applications and applications with reduced requirements with regard to position feedback both versions - with and without motor - are also available without sensOstep™ encoder as PDx-113-57/60 and TCM-113-60 on request.

4 Mechanical and electrical interfacing

4.1 Size of PDx-113-57-SE

Currently, there is a choice between four NEMA 23 / 57mm bipolar stepper motors with different lengths and different holding torques.

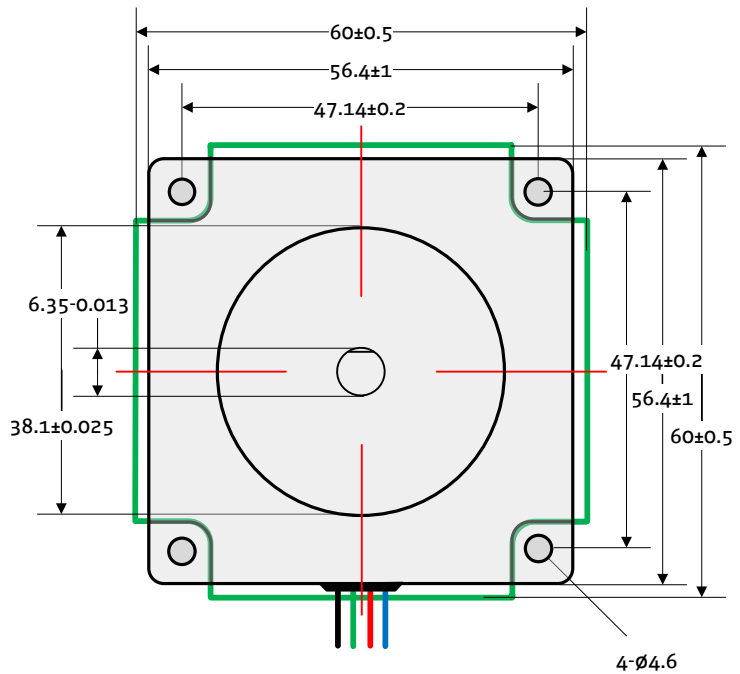
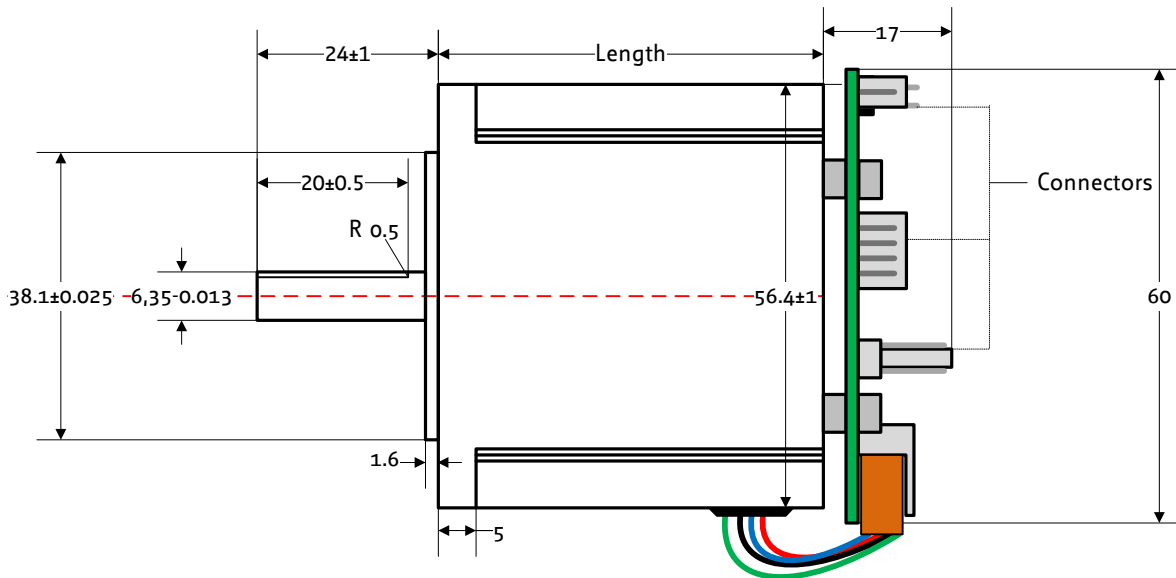

	Length of motor
PD1	41mm
PD2	51mm
PD3	56mm
PD4	76mm

Figure 4.1: Dimensions of PDx-113-57-SE (all values in mm)

4.2 Size of PDx-113-60-SE

Currently, there is a choice between four NEMA 24 / 60mm bipolar stepper motors with different lengths and different holding torques.

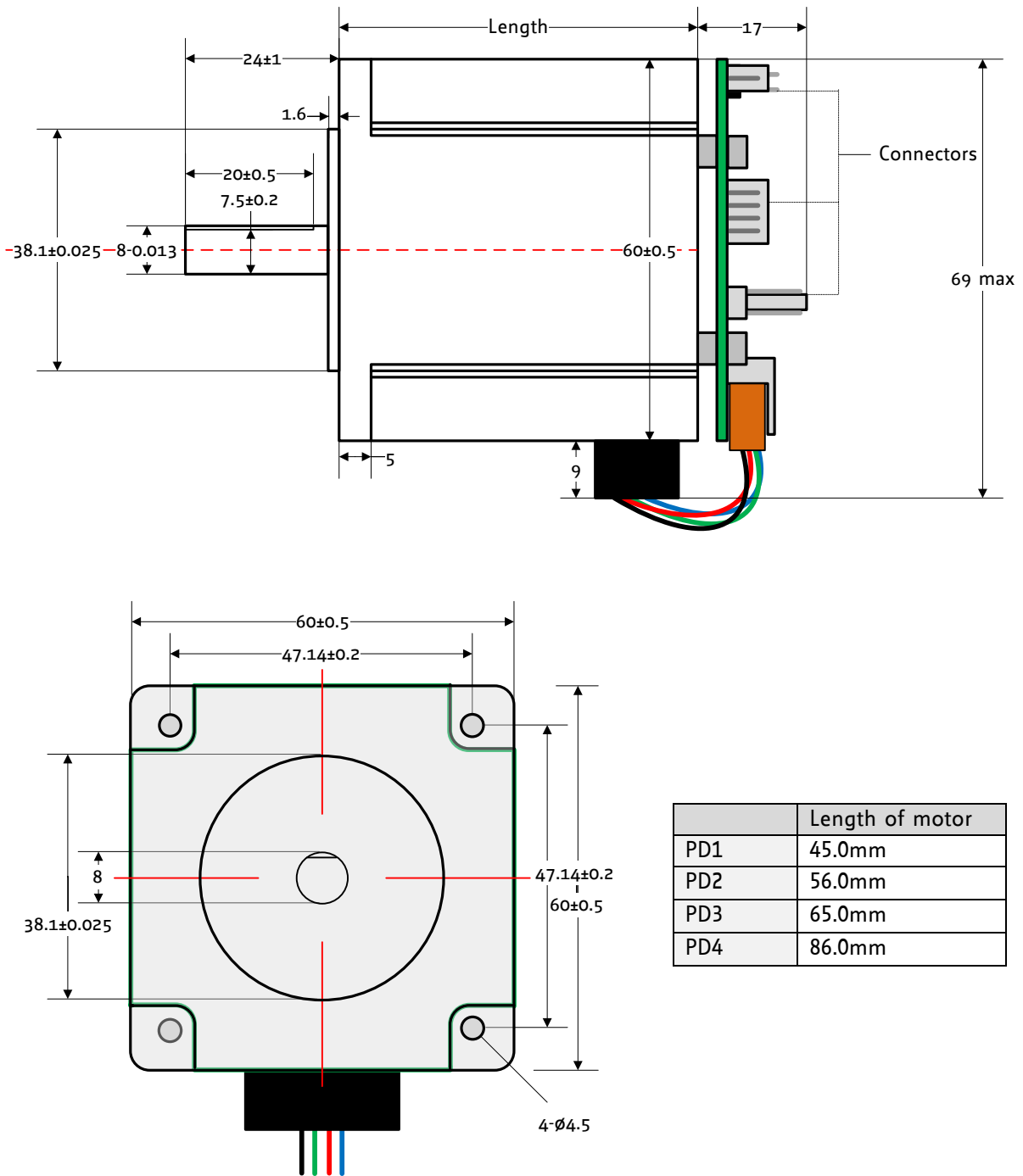

Figure 4.2: Dimensions of PDx-113-60-SE (all values in mm)

4.3 Size of electronics

The outer shape of the TCM-113-60-SE controller/driver board has been designed in order to fit to the back bell of a NEMA 24/60mm flange size motor (60mmx60mm). Consequently, the module is a little bit larger than the motor when being mounted on a standard NEMA 23/57mm motor.

There are four mounting holes altogether. They have been designed in order to fit to the latest NEMA 23/57mm [QSH5718] and NEMA 24/60mm [QSH6018] stepper motors available from TRINAMIC. Two mounting holes at opposite corners of the board have been positioned in order to be able to attach it to the back bell of the NEMA 23/57mm stepper motors and the other two for mounting it to the NEMA 24/60mm stepper motors.

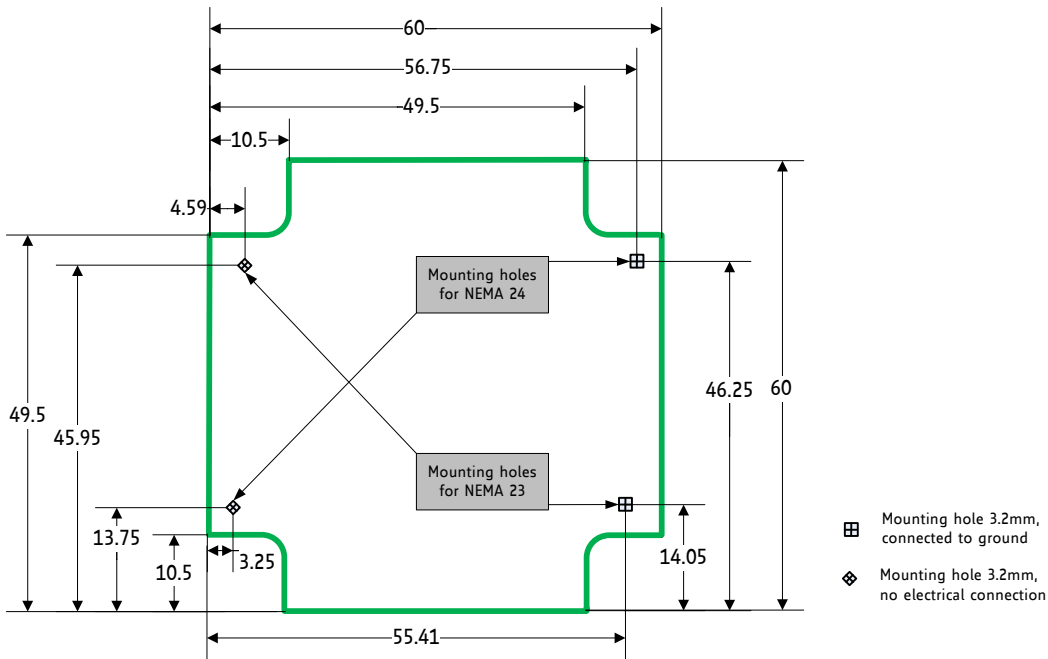

Figure 4.3: PDx-113-57/60-SE controller/driver board

4.4 Motor

Main characteristics of the four different motors available as part of the PDx-113-57-SE:

Specifications	Parameter	Units	QSH5718			
			-41-28-055	-51-28-101	56-28-126	-76-28-189
Number of Leads		N°	4	4	4	4
Step Angle		°	1.8	1.8	1.8	1.8
Step Angle Accuracy		%	5	5	5	5
Rated Voltage	V_{RATED}	V	2	2.3	2.5	3.2
Rated Phase Current	$I_{RMS RATED}$	A	2.8	2.8	2.8	2.8
Phase Resistance at 20°C	R_{COIL}	Ω	0.7	0.83	0.9	1.13
Phase Inductance (typ.)		mH	1.4	2.2	2.5	3.6
Holding Torque		Nm	0.55	1.01	1.26	1.89
Rotor Inertia		g cm ²	120	275	300	480
Insulation Class			B	B	B	B
Max. applicable voltage		V	75	75	75	75
Max. radial force (20mm from front flange)		N	75	75	75	75
Max. axial force		N	15	15	15	15
Weight		kg	0.45	0.65	0.7	1
Length		mm	41	51	56	76
Temp. Rise (rated current, 2 phase on)		°C	+80 max	+80 max	+80 max	+80 max
Ambient Temperature		°C	-20 ... +50	-20 ... +50	-20 ... +50	-20 ... +50

Table 4.1: NEMA 23 / 57mm technical motor data

Main characteristics of the four different motors available as part of the PDx-113-60-SE:

Specifications	Parameter	Units	QSH6018			
			-45-28-110	-56-28-165	-65-28-210	-86-28-310
Number of Leads		N°	8	8	8	8
Step Angle		°	1.8	1.8	1.8	1.8
Rated Voltage	V_{RATED}	V	2.1	2.52	3.36	4.17
Rated Phase Current	$I_{RMS RATED}$	A	2.8	2.8	2.8	2.8
Phase Resistance at 20°C	R_{COIL}	Ω	0.75	0.9	1.2	1.5
Phase Inductance (typ.)		mH	2	3.6	4.6	6.8
Holding Torque		Nm	1.1	1.65	2.1	3.1
Rotor Inertia		g cm ²	275	400	570	840
Insulation Class			B	B	B	B
Weight		kg	0.6	0.77	1.2	1.4
Ambient Temperature		°C	-20 ... +50	-20 ... +50	-20 ... +50	-20 ... +50

Table 4.2: NEMA 24 / 60mm technical motor data

4.5 Connectors

The TCM-113-60-SE has four connectors, a 2-pin connector for power supply, a 4-pin serial communication interface connector, an 8-pin input/output connector and a 4-pin motor connector (used to connect the attached motor).

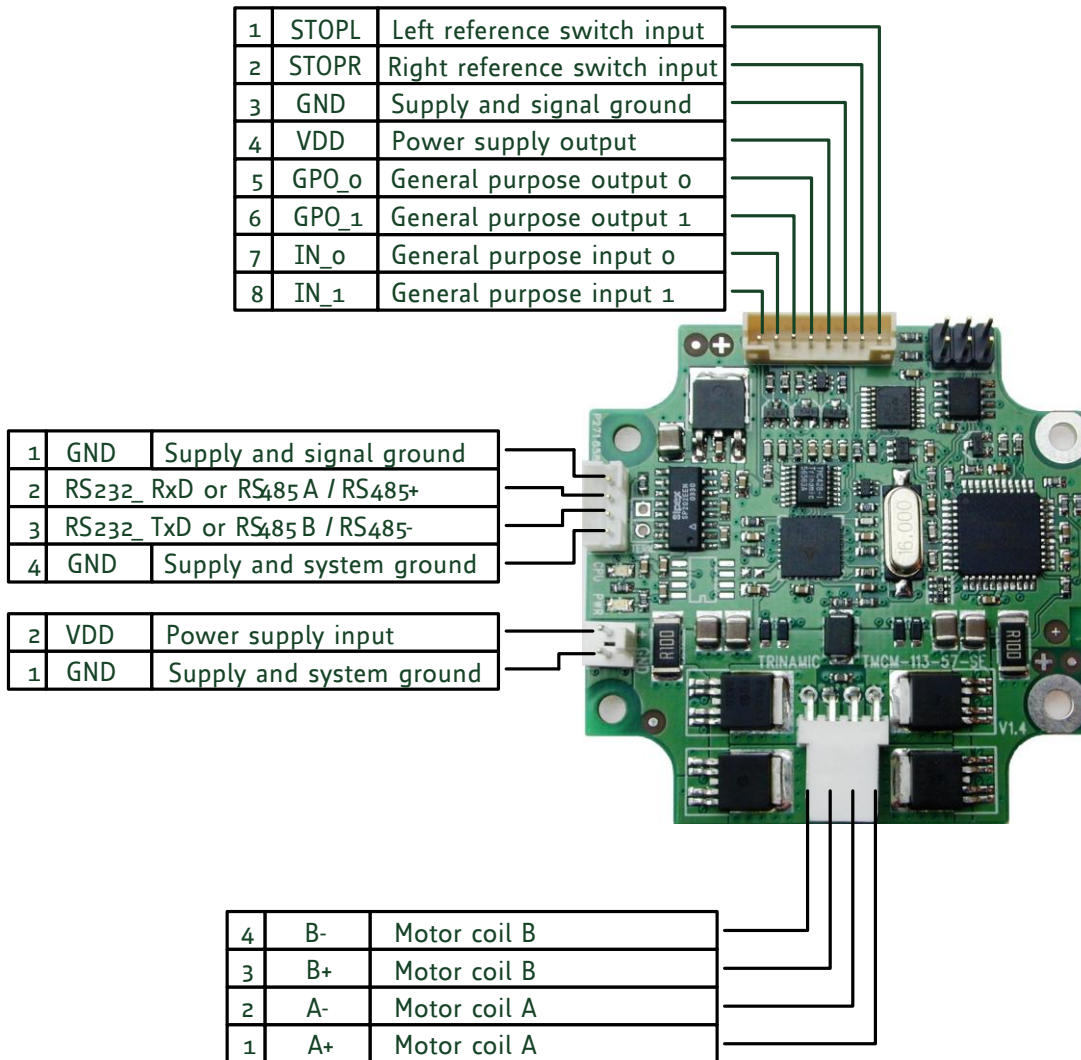

Figure 4.4: TCM-113-60-SE connectors

The following table shows which connector types and their mating connectors are used.

Domain	Connector type	Mating connector type
Power	Molex 22-27-2021, type 6410, 2.54mm KK header, square pin	Molex, 22-01-2025, type 6471, 2.54mm KK female connector; crimp contacts Molex 08-50-0032
Motor	MOLEX 22-05-7048 type 7395, 2.54 mm KK header	MOLEX 22-01-2045, type 6471, 2.54mm KK, female connector; crimp contacts Molex 08-50-0032
RS232/RS485	JST B4B-PH-K, 2.0mm header for crimp connection with top entry	JST PHR-4, 2.0mm, female crimp connector; crimp contacts JST BPH-002T-P0.5S
I/Os and switches	JST B8B-PH-K, 2.0mm header for crimp connection with top entry	JST PHR-4, 2.0mm, female crimp connector; crimp contacts JST BPH-002T-P0.5S

Table 4.3: Connectors and mating connectors

4.5.1 Power connector

A 2-pin Molex 6410 series connector is used for power supply.

	Pin	Label	Description
	1	GND	Module ground (power supply and signal ground)
	2	VDD	Power supply input, nom. +24V DC (+7... +28.5V DC)

Table 4.4: Connector for power

A mating connector together with a cable loom is available as part of the TCM-113-CABLE cable loom set.

4.5.2 Serial communication connector

A 4-pin JST PH series connector is used for serial communication. Two different communication interface standards are available with this unit (either or options): RS232 and RS485.

	Pin	RS232	RS485	Description
	1	GND	GND	Power and signal ground
	2	RS232_RxD	RS485A / RS485+	Serial communication signal
	3	RS232_TxD	RS485B / RS485-	Serial communication signal
	4	GND	GND	Power and signal ground

Table 4.5: Connector for communication

Mating connector from JST: PHR-4 (housing) and SPH-002T-P0.5S (crimp contact for AWG #30 to 24 / 0.05mm² to 0.22mm² wires).

A mating connector together with a cable loom is available as part of the TCM-113-CABLE cable loom set.

4.5.3 I/O connector

An 8-pin JST PH series connector is used for general purpose input/output signals and reference switch inputs.

	Pin	Label	Direction	Description
	1	STOPL	Input	Left reference switch input
	2	STOPR	Input	Right reference switch input
	3	GND	Power	Power and signal ground
	4	VDD	Output	Power supply output
	5	OUT_0	Output	General purpose output (open collector)
	6	OUT_1	Output	General purpose output (open collector)
	7	IN_0	Input	General purpose input (+24V compatible)
	8	IN_1	Input	General purpose input (+24V compatible)

Table 4.6: Connector for stop switches and general purpose I/O

Mating connector from JST: PHR-8 (housing) and SPH-002T-P0.5S (crimp contact for AWG #30 to 24/0.05mm² to 0.22mm² wires).

A mating connector together with a cable loom is available as part of the TCM-113-CABLE cable loom set.

4.5.4 Motor connector

A 4-pin Molex 7395 series connector is used for connecting the motor.

	Pin	Label	Direction	Description
	1	A+	Output	2-phase stepper motor phase A
	2	A-	Output	2-phase stepper motor phase A
	3	B+	Output	2-phase stepper motor phase B
	4	B-	Output	2-phase stepper motor phase B

Table 4.7: Connector for motor

A mating connector together with a cable loom is available as part of the TCM-113-CABLE cable loom set.

4.6 Serial communication interface

The PDx-113-57/60-SE is available with two serial interface options: RS232 for point-to-point communication and RS485 for bus communication. The two different interface options are assembly options – depending on the desired interface different components are assembled.

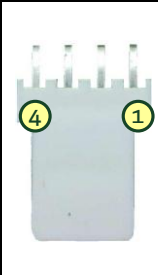
4.6.1 RS232

RS232 can be used for serial point-to-point communication. The PDx-113-57/60-SE-232 includes a transceiver with level converter for true RS232/V24 signal levels (Figure 4.3).

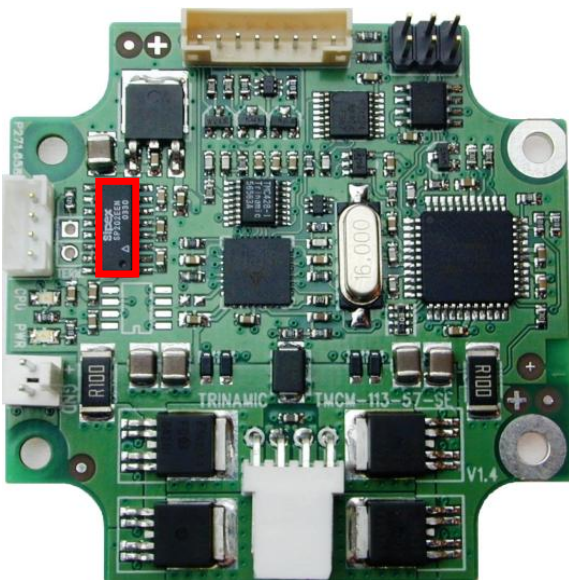

Figure 4.5: RS232 interface option (transceiver/level shifter IC marked red)

When connecting to a master e.g. PC using the RS232 interface please keep in mind that the RS232 **transmit** signal wire of the master has to be connected to the RS232 **receive** signal wire of the board and vice versa.

CONNECTION BETWEEN PC AND PDx-113-57/60-SE

PC (D-SUB 9pin)		PDx-113-57/60-SE (Serial communication connector)	
Pin	Label	Pin	Label
2	RS232_RxD	3	RS232_TxD
3	RS232_TxD	2	RS232_RxD
5	GND	1, 4	GND

Table 4.8: RS232 Connection PC <-> PDx-113-57/60-SE

4.6.2 RS485

RS485 can be used for serial bus communication. The PDx-113-57/60-SE-485 includes a transceiver and a termination resistor which can be activated for modules placed at one end of the communication bus using an on-board jumper (Figure 4.6).

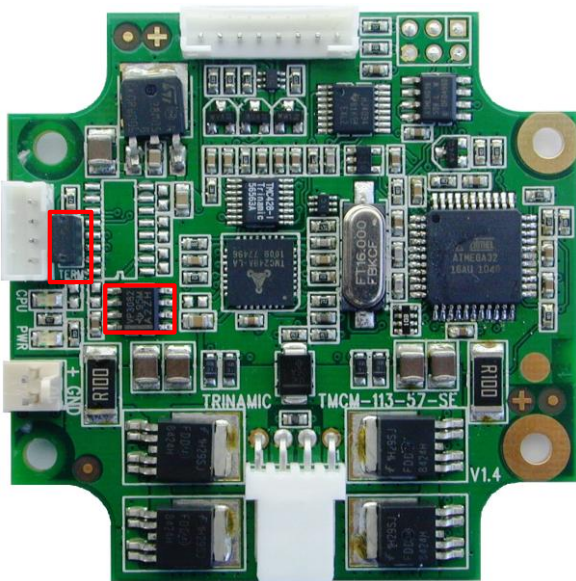

Figure 4.6: RS485 interface option (transceiver and termination header marked red)

For proper operation of the RS485 bus the following items should be taken into account when setting up an RS485 network:

BUS STRUCTURE: The network topology should follow a bus structure as closely as possible. That is, the connection between each node and the bus itself should be as short as possible. Basically, it should be short compared to the length of the bus.

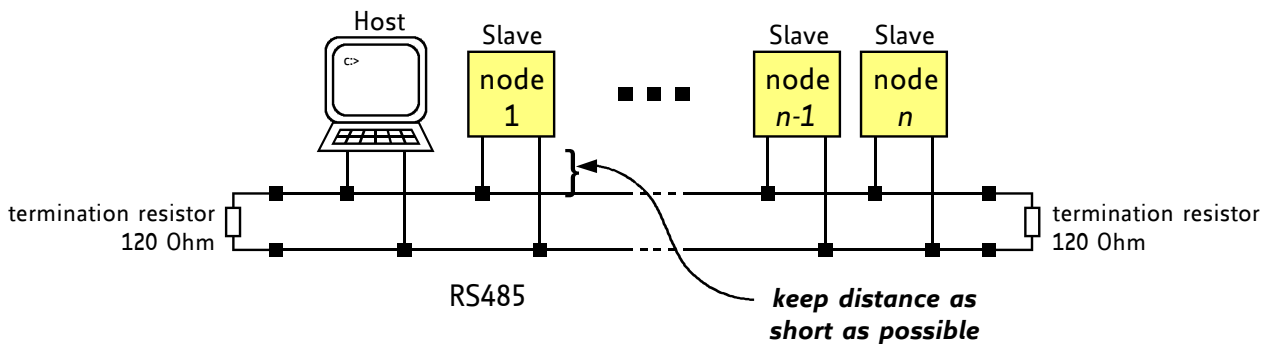

Figure 4.7: Bus structure

BUS TERMINATION: Especially for longer busses and/or multiple nodes connected to the bus and/or high communication speeds, the bus should be properly terminated at both ends. The PDx-113-57/60-SE-485 integrates a 120 Ohm termination resistor that can be placed between both RS485 bus wires by setting a jumper.



Figure 4.8: Jumper for placing bus termination

NUMBER OF NODES: The RS485 electrical interface standard (EIA-485) allows up to 32 nodes to be connected to a single bus. The bus transceiver used for the PDx-113-57/60-SE-485 units (SN65HVD3082ED) has just 1/8 of the standard bus load and allows a maximum of 256 units to be connected to a single RS485 bus.

NO FLOATING BUS LINES: Avoid floating bus lines while neither the host/master nor one of the slaves along the bus line is transmitting data (all bus nodes switched to receive mode). Floating bus lines may lead to communication errors. In order to ensure valid signals on the bus it is recommended to use a resistor network connecting both bus lines to well defined logic levels. In contrast to the termination resistors this network is normally required just once for a bus. Certain RS485 interface converters available for a PC already include these additional resistors (e.g. USB-2-485 [USB-2-485]).

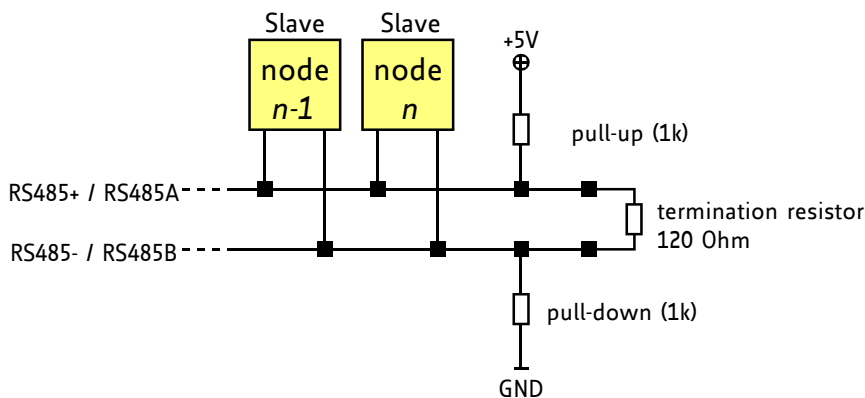

Figure 4.9: Resistor network to avoid floating bus lines

4.7 Reference switch inputs

There are 2 reference/stop switch inputs (STOPL / STOPR). Both inputs offer an internal pull-up resistor (1k) and accept voltages between 0 and +5V.

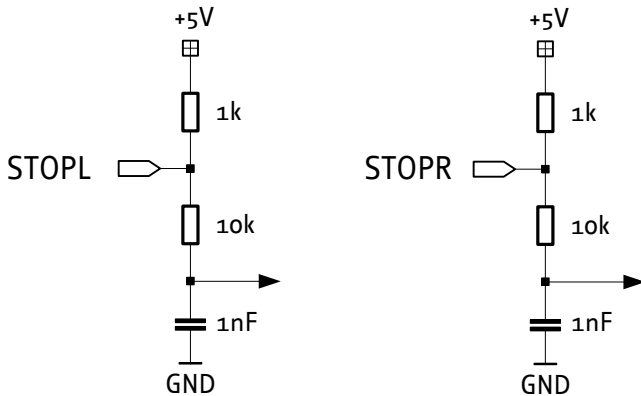

Figure 4.10: Reference/stop switch inputs STOPL, STOPR

4.8 General purpose inputs

There are 2 general purpose inputs (IN_0 / IN_1). Both inputs offer internal voltage divider and voltage limiter and accept input voltages between 0 and +24V. The voltage divider resistors act as pull-down resistors, also. Both inputs accept digital and analogue signals (depending on software configuration).

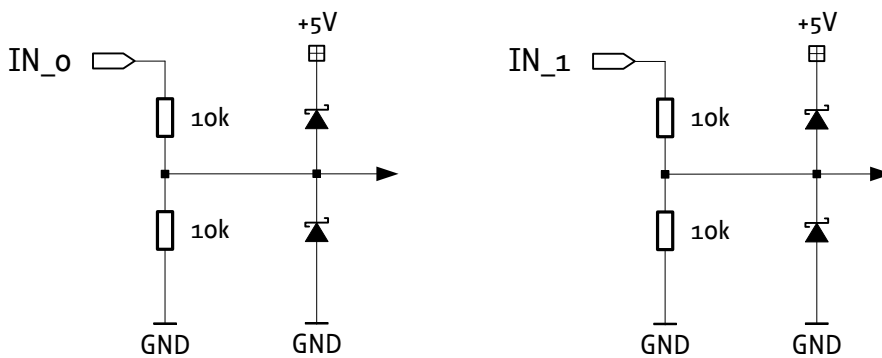

Figure 4.11: General purpose inputs IN_0, IN_1

4.9 General purpose outputs

There are 2 general purpose outputs (OUT_0 / OUT_1). Both outputs are open collector outputs and can drive loads up to 100mA. Especially for inductive loads a freewheeling diode to supply voltage (VDD) has been included. This is also the reason why the external voltage at the general purpose outputs - when the outputs are switched off - should not be higher than the supply voltage of the module + approx. 0.5V.

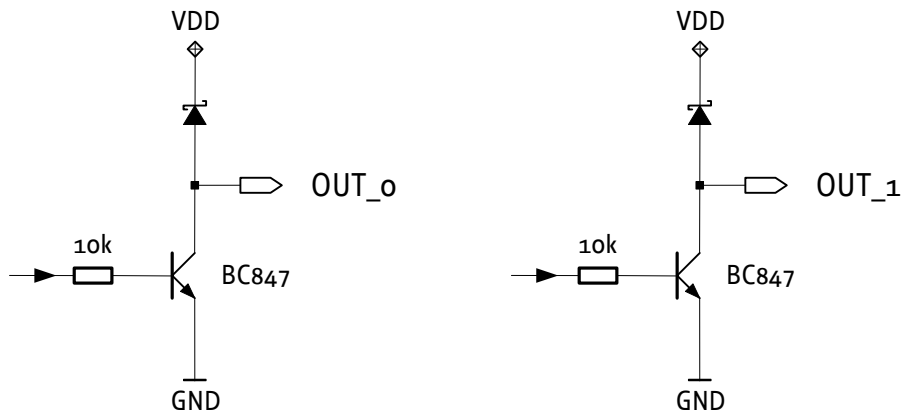

Figure 4.12: General purpose outputs OUT_0, OUT_1

5 Operational ratings

The operational ratings shown below should be used as design values. In no case should the maximum values be exceeded during operation.

Symbol	Parameter	Min	Type	Max	Unit
V_{DD}	Power supply voltage for operation	7	24	28.5	V
I_{COIL_peak}	Motor coil current for sine wave peak (chopper regulated, adjustable via software)	0		4 *)	A
I_{COIL_RMS}	Continuous motor current (RMS)	0		2.8 *)	A
I_{SUPPLY}	Power supply current		$\ll I_{COIL}$	$1.4 * I_{COIL}$	A
T_{ENV}	Environment temperature at rated current (no forced cooling required)	-20		+40 **)	°C
	Environment temperature at 80% of rated current or 50% duty cycle (no forced cooling required)	-20		+60	°C

Table 5.1: General operational ratings of the module

*) Please note: only PDx-113-57/60-SE and TCM-113-60-SE with pcb version 1.2 or newer support specified max. current over full temperature range. Older or pre-series versions may be limited with regard to temperature range and / or max. motor current.

***) Test set-up / procedure: PANdrive PD4-113-60-SE mounted to a metal base plate in order to keep stepper motor temperature within limits for the motor during test (table 4.2) / test inside climate chamber with approx. 53l volume / no forced air convection during test / test duration at least 30min.

Please note: motor temperature should always be kept below upper limit for the motor - that is, motor / PANdrive should be mounted to an appropriate metal / cooling plate or frame. Especially, the longer available stepper motor which are part of the PD4-113-57-SE or PD4-113-60-SE may easily reach 100°C or above when operated at full current over long time without being mounted to any heat-conducting structure or forced air convection. In case the TCM-113-60-SE electronic module is mounted close to the motor as with the PANdrives, the motor might substantially heat up the electronics and limit the maximum environmental temperature during operation. The unit may be operated at higher environmental temperatures than specified when the duty cycle of the motor and / or the motor current is reduced or in case the TCM-113-60-SE electronic module is mounted separately from the motor.

Symbol	Parameter	Min	Type	Max	Unit
$V_{STOPL/R}$	Input voltage for STOPL/R	0		5	V
V_{STOPL/R_L}	Low level voltage for STOPL/R	0		1.2	V
V_{STOPL/R_H}	High level voltage for STOPL/R (internal 1k pull-up)	1.9		5	V
$V_{IN_0/1_digital}$	Input voltage for IN_0 and IN_1 when used as digital input	0		24	V
$V_{IN_0/1_analogue}$	Input voltage for IN_0 and IN_1 when used as analogue input	0		10	V
$V_{IN_0/1_L}$	Low level voltage for IN_0 and IN_1 when used as digital input (internal 20k pull-down)	0		2	V
$V_{IN_0/1_H}$	High level voltage for IN_0 and IN_1 when used as digital input	6		24	V
$V_{OUT_0/1}$	Voltage at open collector output	0		$V_{DD} + 0.5 *$)	V
$I_{OUT_0/1}$	Output sink current			100	mA

Table 5.2: Operational ratings of the general purpose inputs/outputs

*) limited to module supply voltage +0.5V due to integrated freewheeling diode between general purpose output and module supply voltage

Symbol	Parameter	Min	Type	Max	Unit
N_{RS485}	Number of nodes connected to single RS485 network			256	

Table 5.3: Operational ratings of the RS485 interface

6 Functional description

The PD-113-57/60-SE is a full mechatronic solution including a 57 or 60 mm flange motor (NEMA23/NEMA24). It combines a convenient controller electronic and a sensOstep™ encoder with a range of different motor types and can be controlled via RS232 or RS485 interface. The chopSync™ feature allows high velocity operation avoiding resonances. The PD-113-57/60-SE comes with the PC based software development environment TMCL-IDE for the Trinamic Motion Control Language (TMCL). Using predefined TMCL high level commands like *move to position* or *constant rotation* a rapid and fast development of motion control applications is guaranteed. Communication traffic is kept very low since all time critical operations, e.g. ramp calculation are performed onboard. The stepper driver / controller module is available without the electronics also as TCM-113-60-SE.

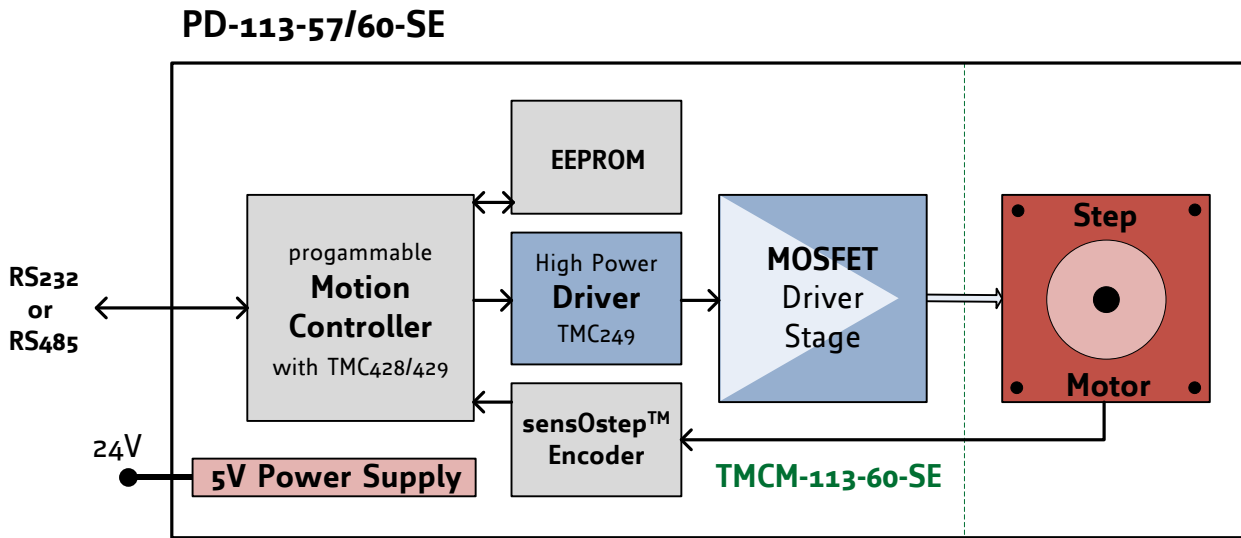

Figure 6.1: Main parts of the PD-113-57/60-SE

7 Torque curves

7.1.1 PD1-113-57-SE

TMCM113 - QSH5718-41-28-055 - Torque versus Velocity
 $V_S = 24 \text{ V}$, $I_{\text{coil}} = 2.8 \text{ A [RMS]}$

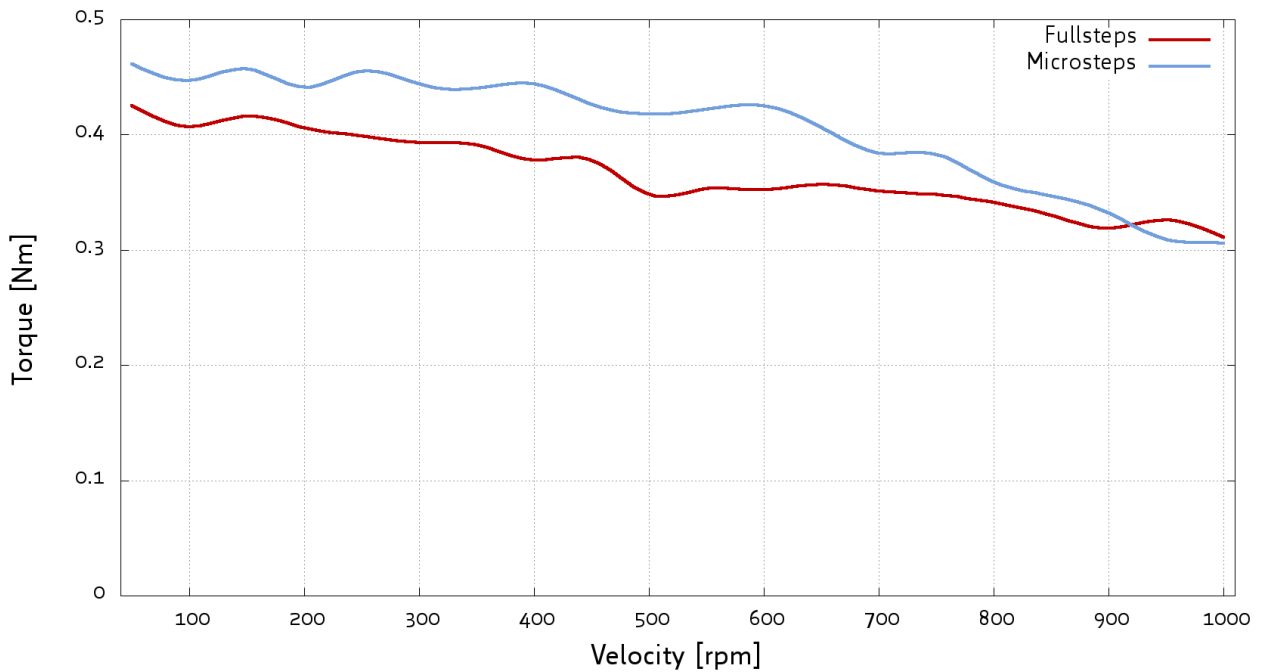

Figure 7.1: Torque curve for PD1-113-57-SE

7.1.2 PD2-113-57-SE

TMCM113 - QSH5718-51-28-101 - Torque versus Velocity
 $V_S = 24 \text{ V}$, $I_{\text{coil}} = 2.8 \text{ A [RMS]}$

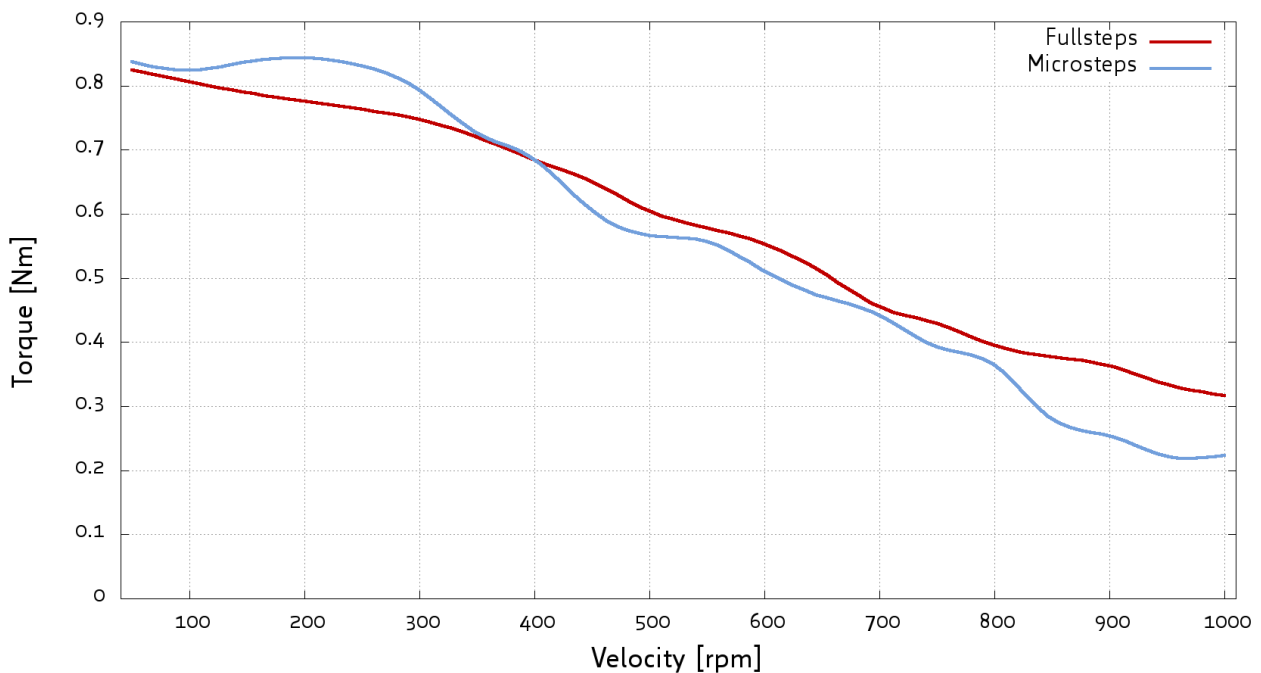

Figure 7.2: Torque curve for PD2-113-57-SE

7.1.3 PD3-113-57-SE

TMCM113 - QSH5718-56-28-126 - Torque versus Velocity
 $V_S = 24 \text{ V}$, $I_{\text{coil}} = 2.8 \text{ A [RMS]}$

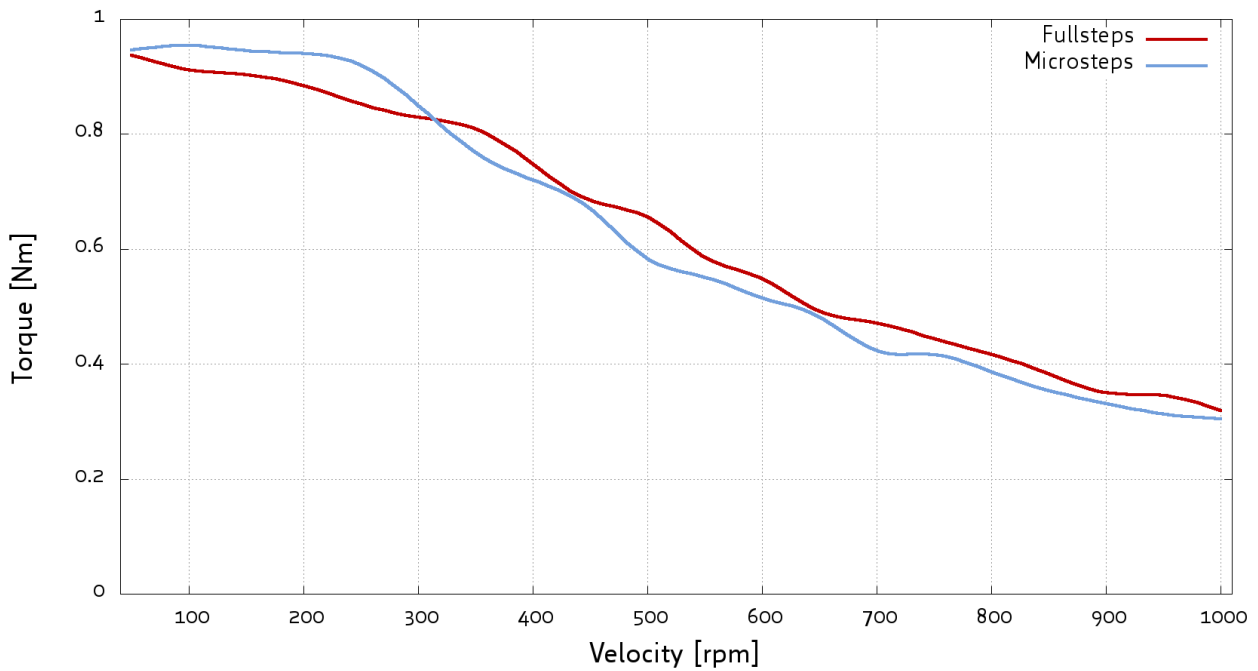

Figure 7.3: Toque curve for PD3-113-57-SE

7.1.4 PD4-113-57-SE

TMCM113 - QSH5718-76-28-189 - Torque versus Velocity
 $V_S = 24 \text{ V}$, $I_{\text{coil}} = 2.8 \text{ A [RMS]}$

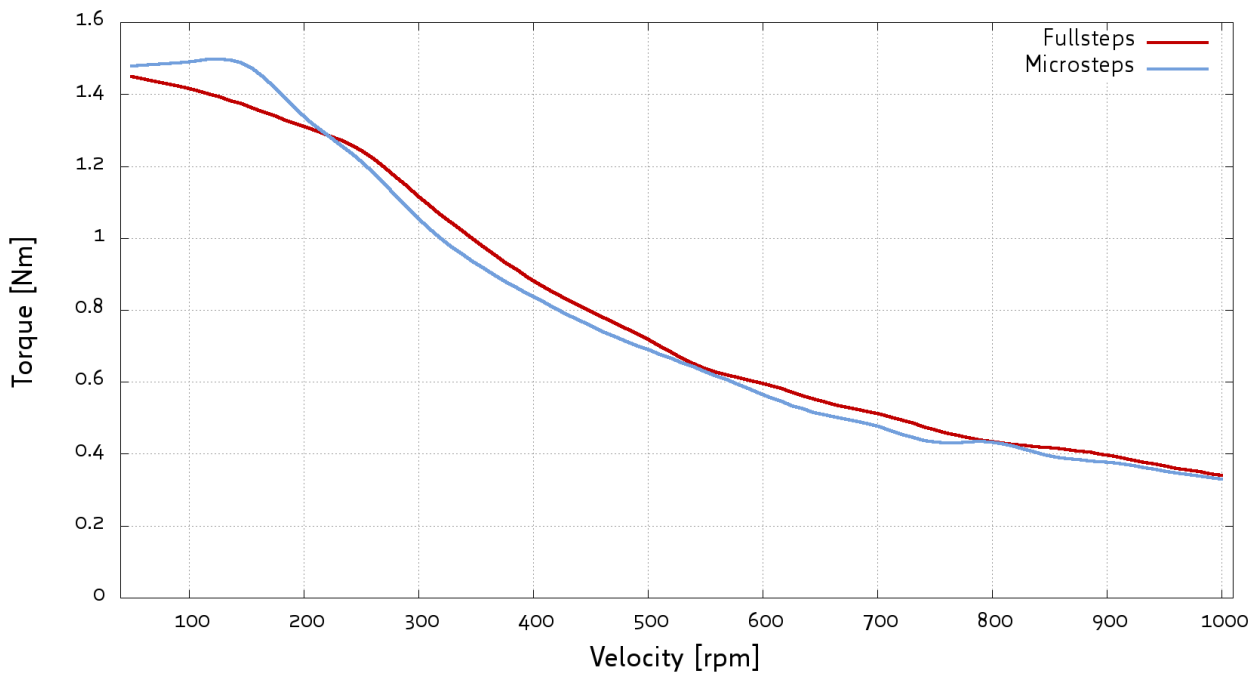

Figure 7.4: Torque curve of PD4-113-57-SE

7.1.5 PD1-113-60-SE

TMCM113 - QSH6018-45-28-110 - Torque versus Velocity
 $V_S = 24\text{ V}$, $I_{\text{coil}} = 2.8\text{ A [RMS]}$

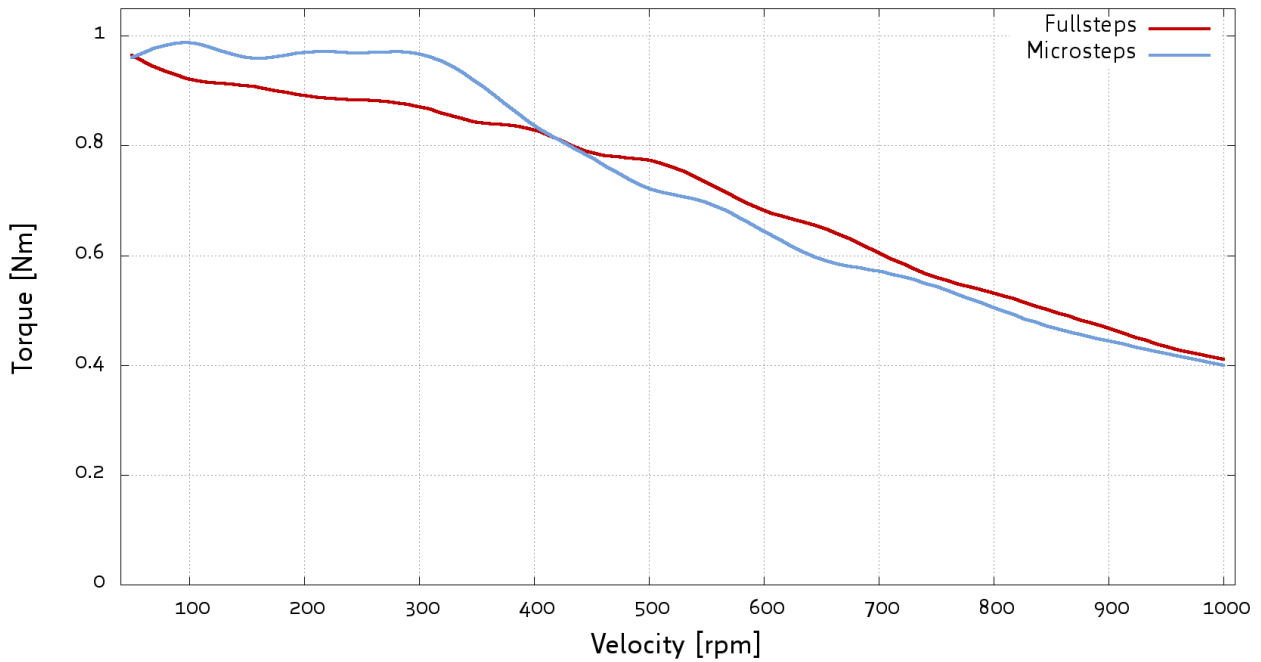

Figure 7.5: Torque curve of PD1-113-60-SE

7.1.6 PD2-113-60-SE

TMCM113 - QSH6018-56-28-165 - Torque versus Velocity
 $V_S = 24\text{ V}$, $I_{\text{coil}} = 2.8\text{ A [RMS]}$

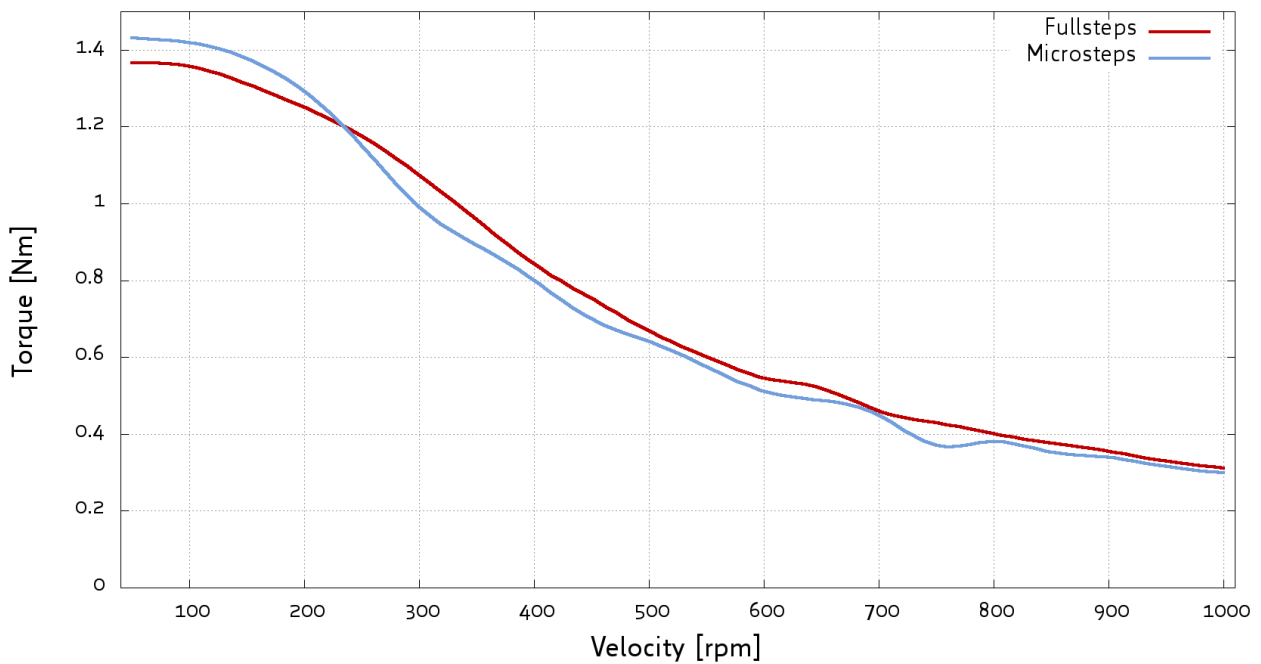

Figure 7.6: Torque curve for PD2-113-60-SE

7.1.7 PD3-113-60-SE

TMCM113 - QSH6018-65-28-210 - Torque versus Velocity
 $V_S = 24\text{ V}$, $I_{coil} = 2.8\text{ A [RMS]}$

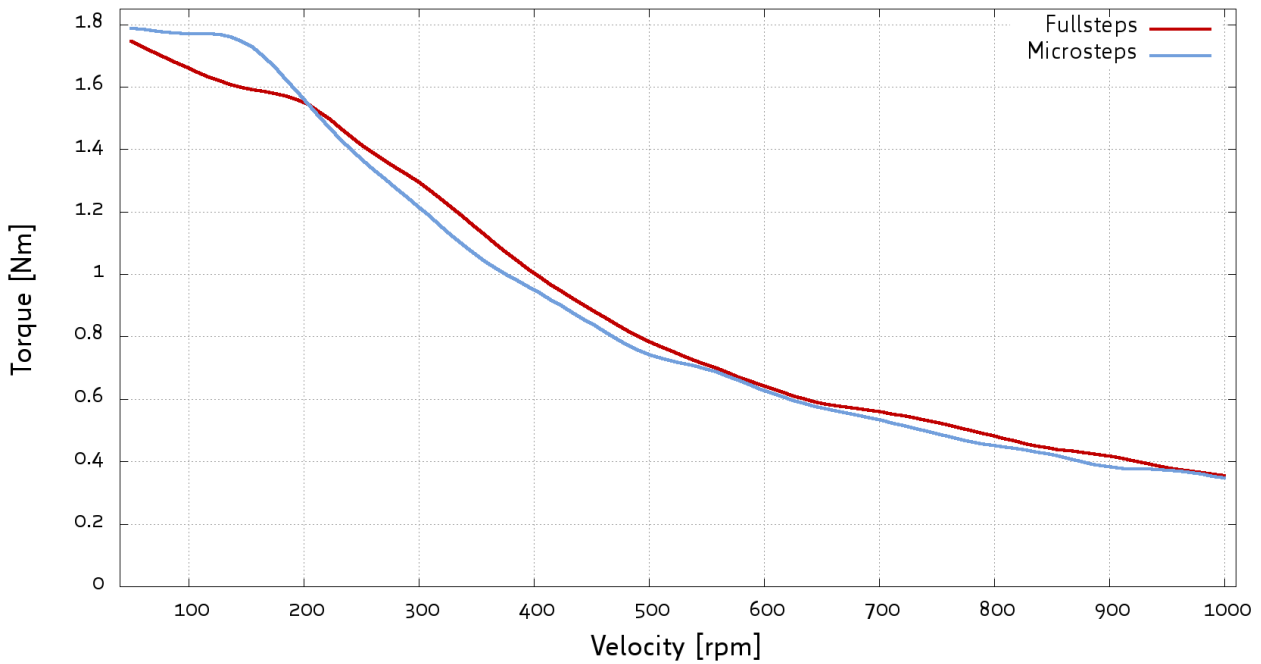

Figure 7.7: Torque curve for PD3-113-60-SE

7.1.8 PD4-113-60-SE

TMCM113 - QSH6018-86-28-310 - Torque versus Velocity
 $V_S = 24\text{ V}$, $I_{coil} = 2.8\text{ A [RMS]}$

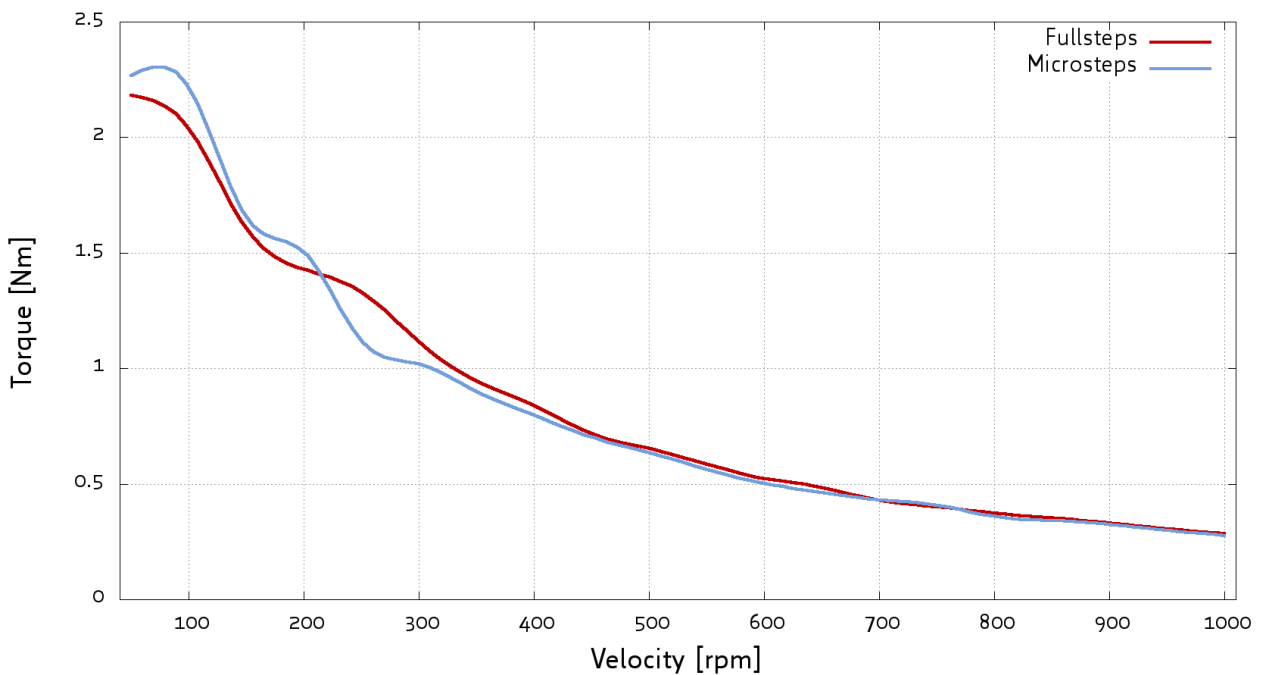

Figure 7.8: Torque curve for PD4-113-60-SE

8 Revision history

8.1 Document revision

Version	Date	Author	Description
1.00	2008-OCT-20	GE	Initial version
1.10	2008-DEC-19	SD	Dimensions of the PANdrives and functional description added
1.20	2009-MAY-13	SD	PD3-113-57-SE and PD4-113-57-SE added
1.30	2009-OCT-28	GE	New hardware version and torque curves added
1.40	2009-DEC-01	GE	TCCM-113-60, name of electronic board corrected
1.41	2010-JUL-30	GE	Incomplete torque curves removed
1.42	2011-MAR-14	SD	Torque curves added, front page new, length of axis corrected (PDx-113-57-SE)
1.43	2011-JUN-02	SD	Information about mating connectors added, new front
1.44	2011-JUN-08	SD	Chapter Fehler! Verweisquelle konnte nicht gefunden werden. added
1.50	2011-SEP-05	SD	Minor changes

Table 8.1: Document revision

8.2 Hardware revision

Version	Date	Description
1.00	2008-JUL-25	First three prototypes
1.10	2008-SEP-24	Minor corrections, start of series production
1.20	2009-JUN-10	Optimisation of thermal design
1.30	2009-AUG-05	SensOstep™ Encoder connection corrected, series production version
1.40	2010-APR-29	Exchange of power MOSFETs

Table 8.2: Hardware revision

9 References

[TMC428/429]	TMC428 / TMC429 Datasheet
[TMCL]	PDx-113-57/60-SE TMCL firmware manual
[QSH5718]	57mm stepper motor manual
[QSH6018]	60mm stepper motor manual
[USB-2-485]	USB-2-485 interface converter manual

See <http://www.trinamic.com>